

Synerjet M3C System

Maxxer 450i

MXU 500i IRS

UXV 500i

TECHNICAL TRAINING MATERIALS



ATV EFI DIAGRAM

KEY ON



FUEL PUMP

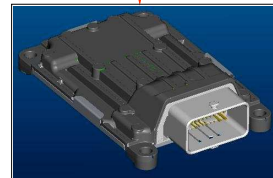

ECU

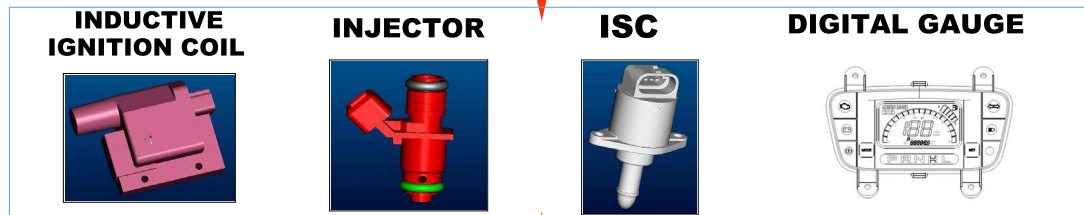

KEY OFF



PART LOCATION- Maxxer 450i

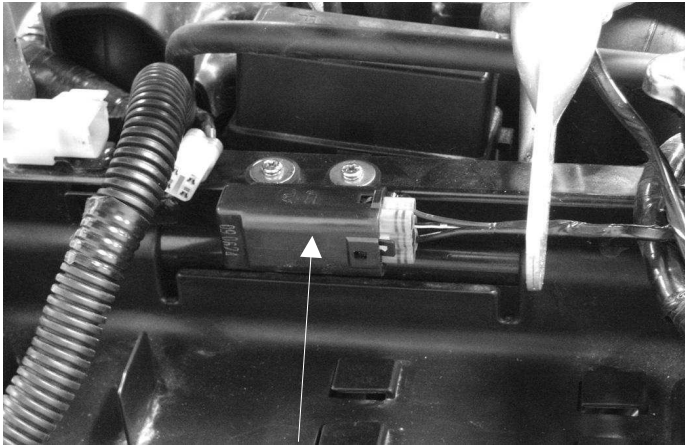

Roll Sensor

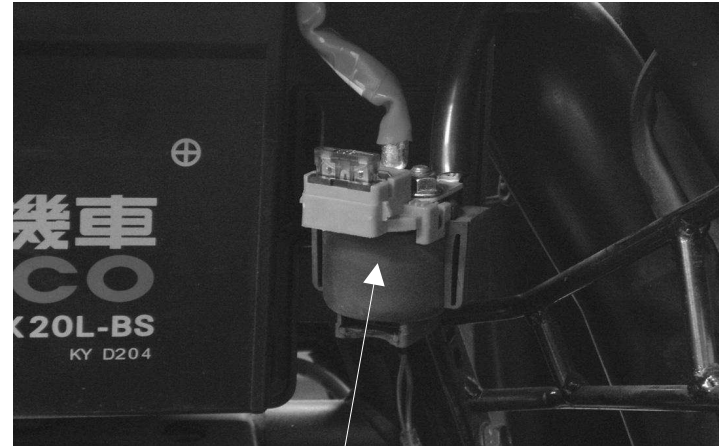

Start Relay



Maxxer 450i

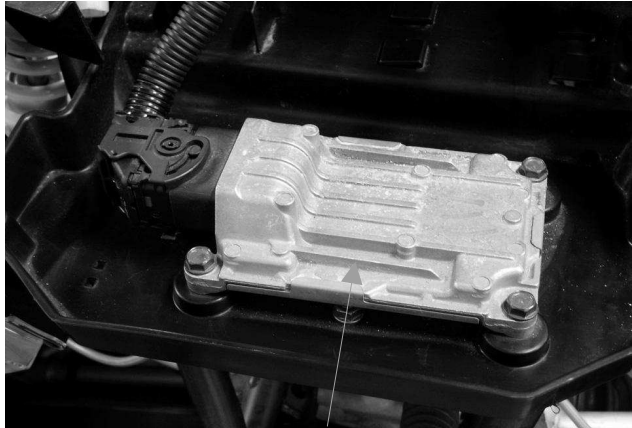

ECU

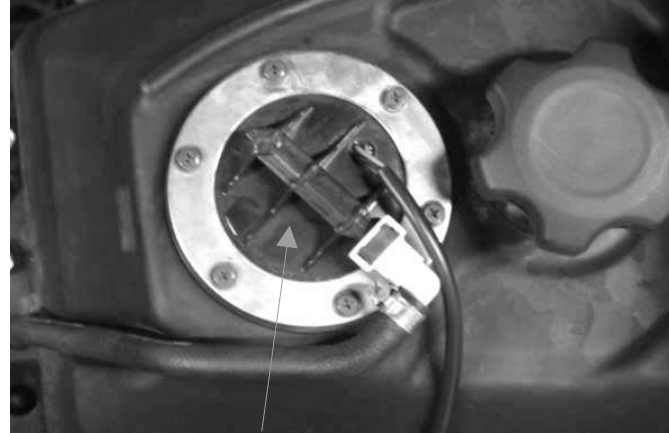

Fuel Pump

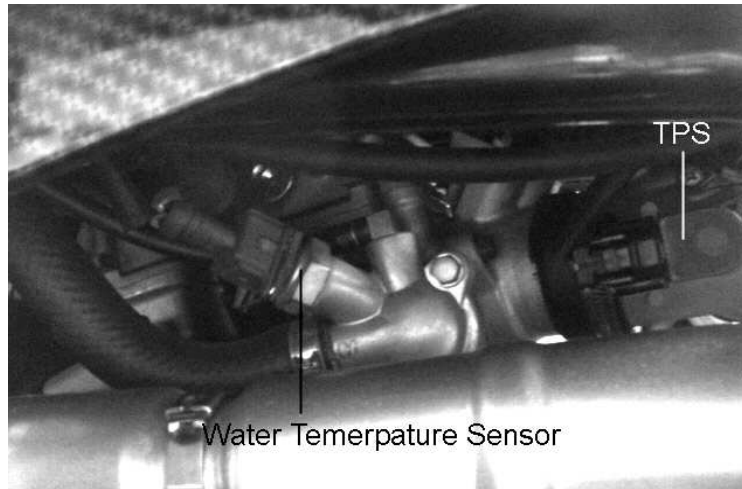

Water Temperature Sensor

TPS



PART LOCATION- MXU 500i

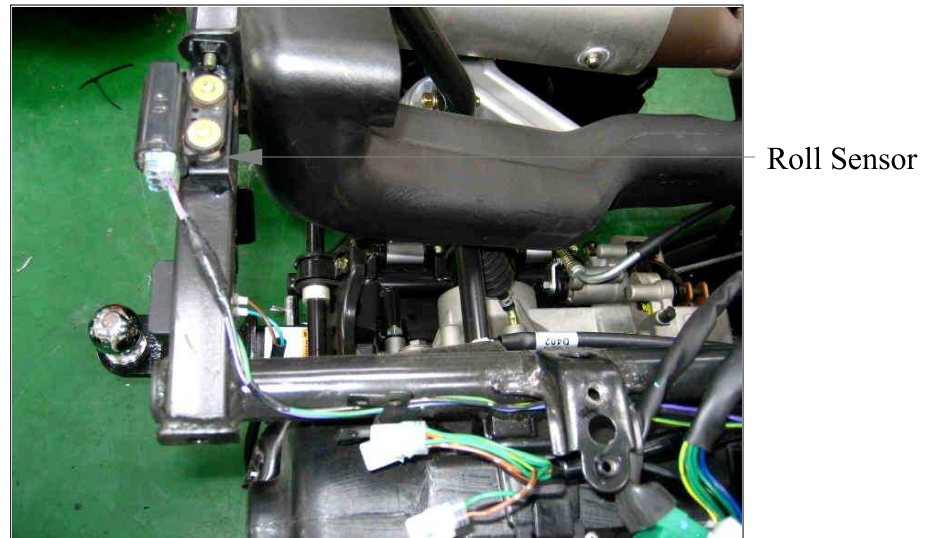

MXU 500i

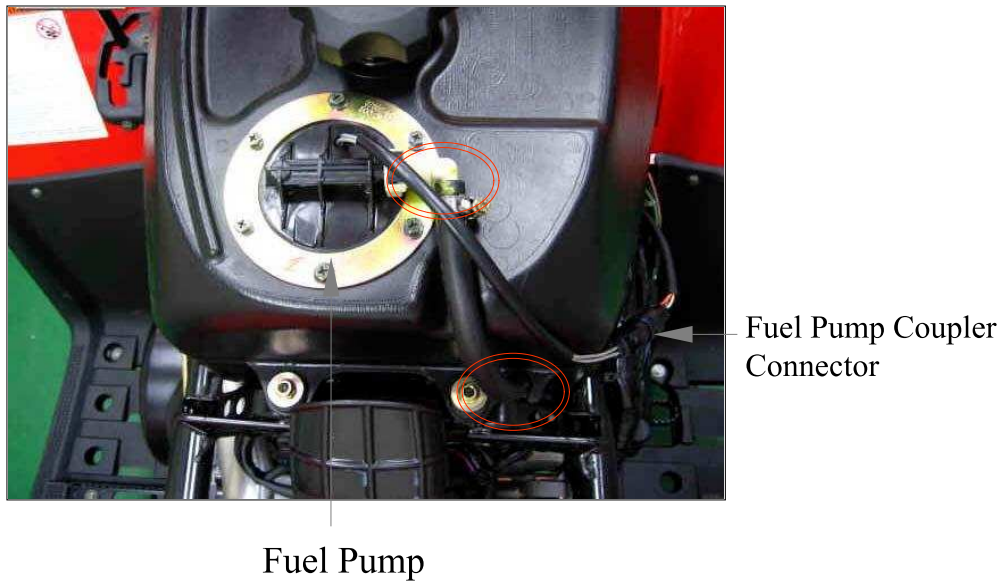

MXU 500i

Inductive
Ignition
Coil

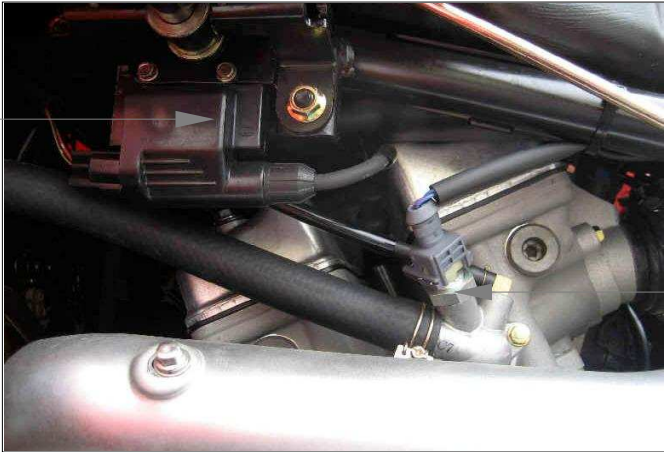

WTS

SW Power/Fuel relay



Start Relay

Battery

Fan/Start Relay



MXU 500i

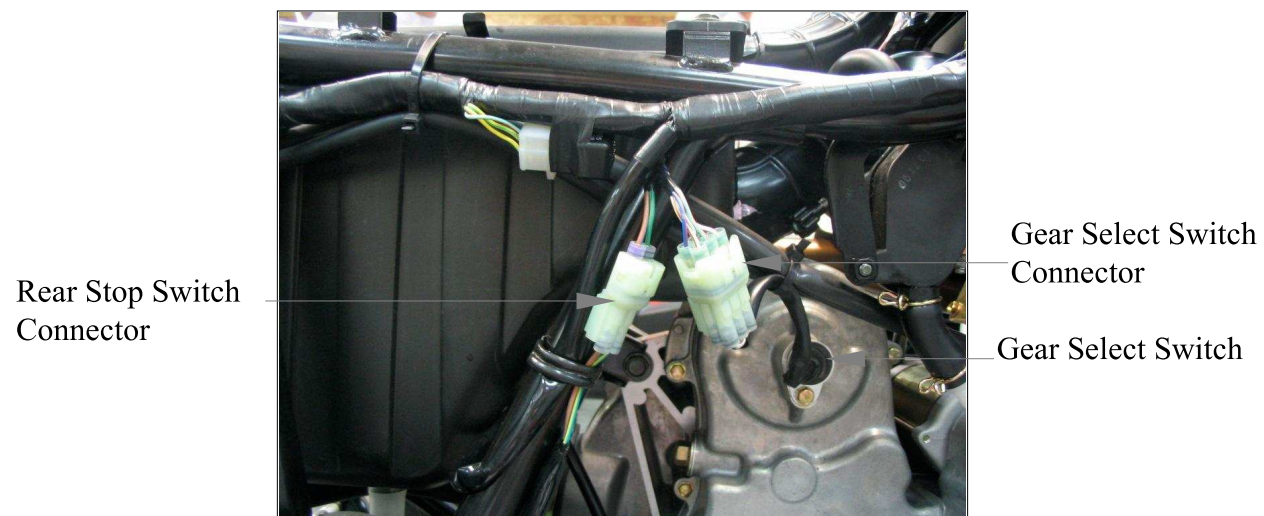
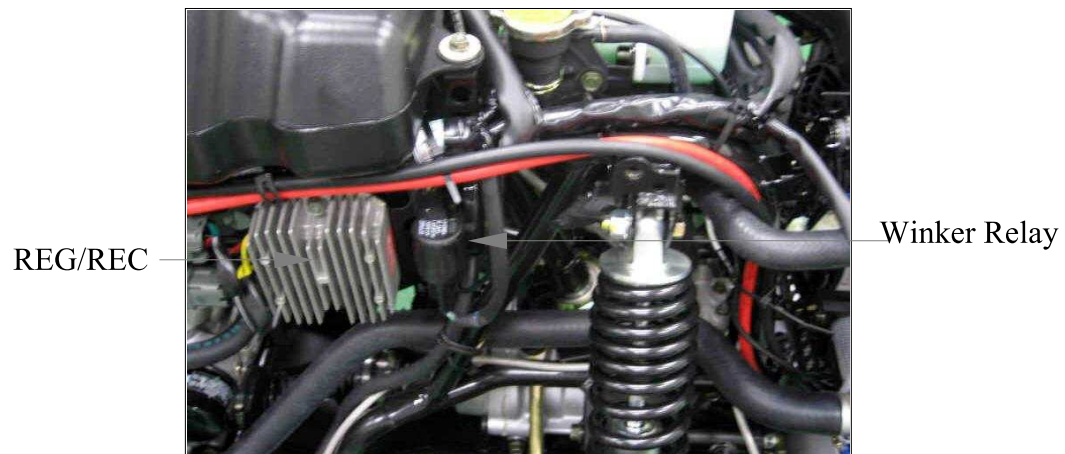

UXV 500i



ECU

ECU
Connector



T-MAP
Sensor

Inlet Pipe

TPS

Fuel Injector

Throttle Body

ISC



UXV 500i

Inductive
Ignition
Coil

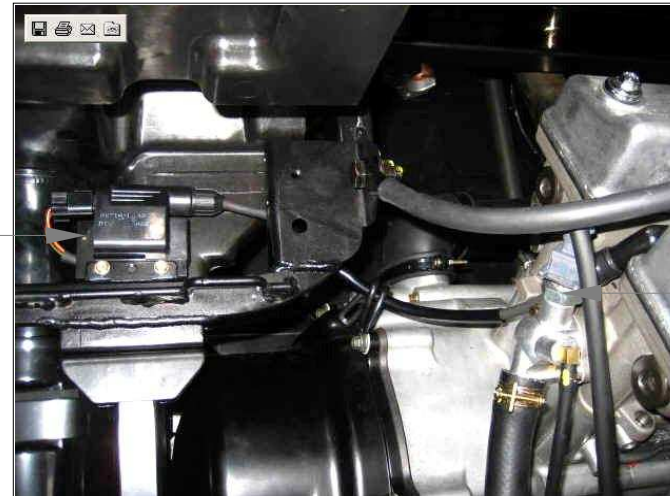

WTS

Hi Beam Relay



Battery

Lo Beam Relay Start Relay



UXV 500i

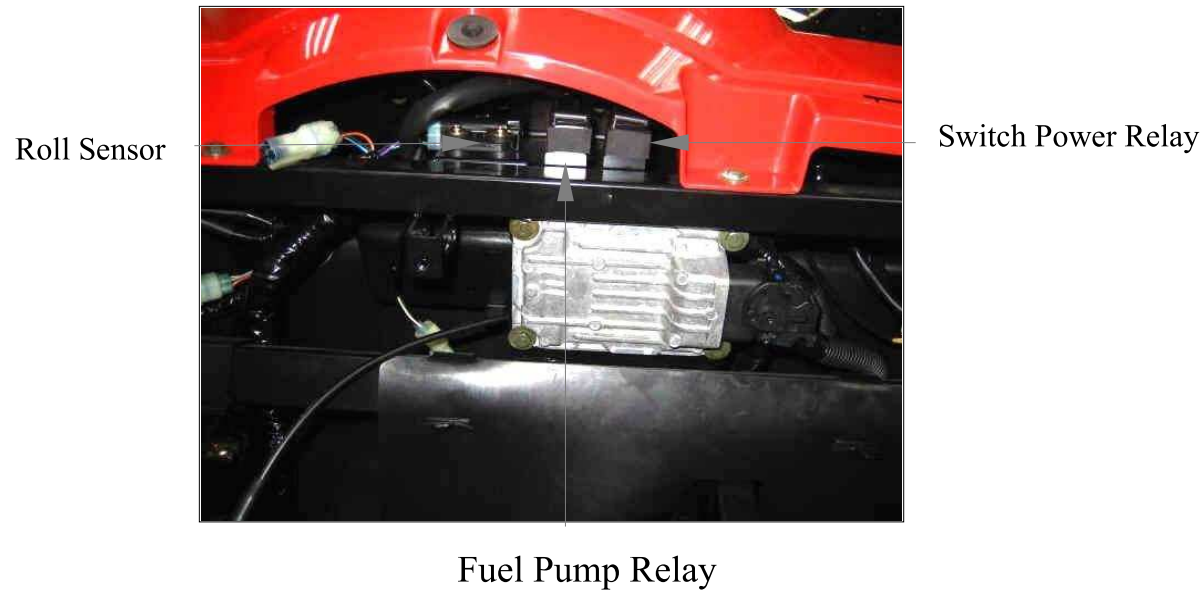
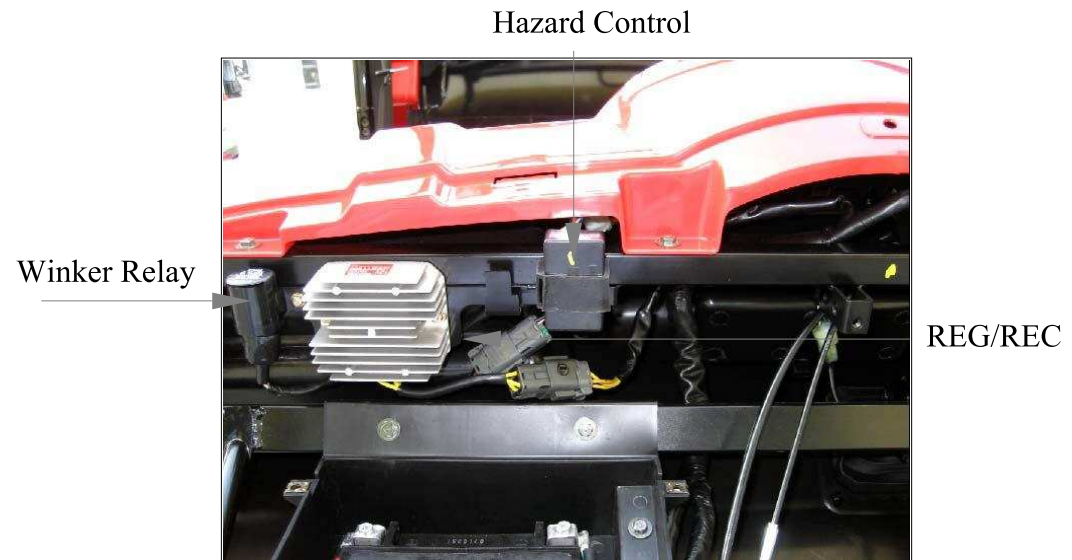

UXV 500i



Fuel Pump Fuel Hose

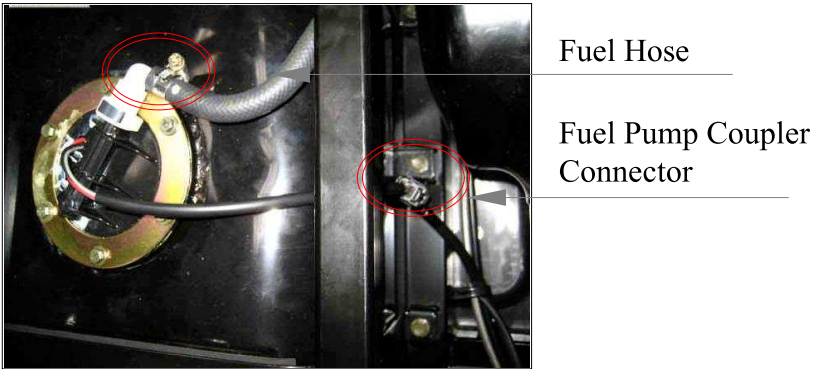

SELF-DIAGNOSTIC PROCEDURES

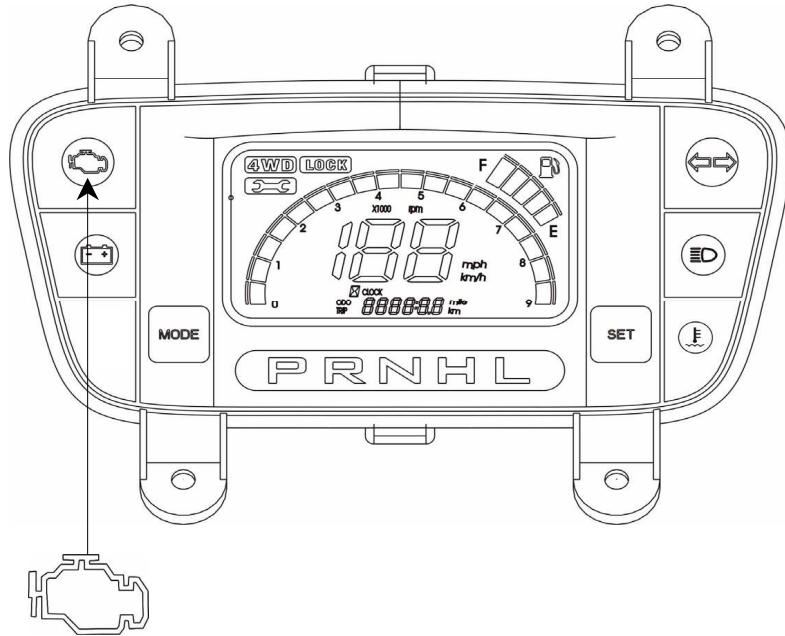

CHECK ENGINE LAMP (CELP)

- Turn the ignition switch to "ON" position
- The CELP indicator will be lighting until the engine starting
- If no failure code, the CELP indicator would be turned off.
- If the failure code happens, the CELP indicator would be turned on

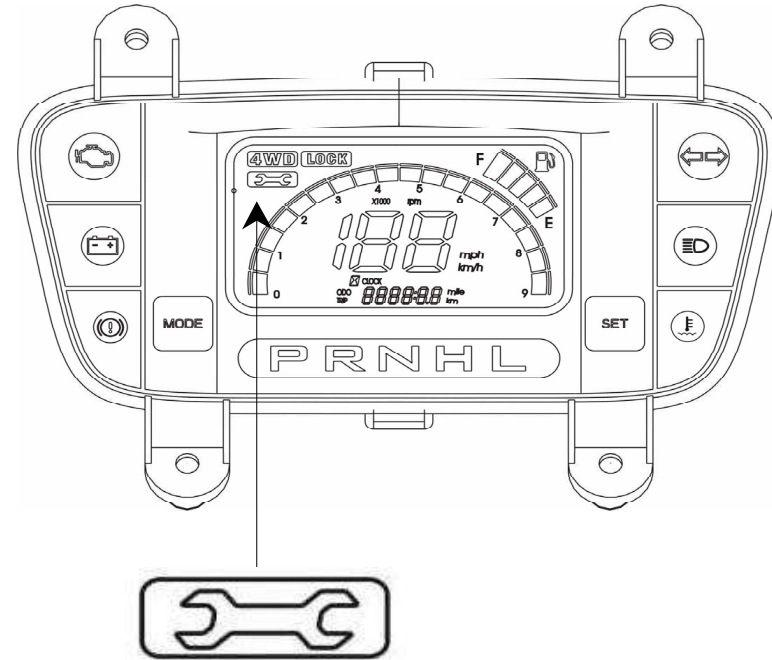

EFI system electric parts fault indicator

- Turn the ignition switch to "ON" position
- The indicator will be lighting until the engine starting
- If no failure code, the indicator would be turned off.
- If the failure code happens, the indicator would be turned on



Failure Codes List

Blinks	Failure Codes	Fault description	Priority	Fault management
1	P0115	Engine temperature overheat	1	1.Slow down the vehicle and go to workshop for checking immediately. 2.Confirm if the engine temperature sensor or electric circuit is abnormality.
2	P0335	Crankshaft position sensor or circuit malfunction	2	1.Check if the connector of crankshaft position sensor is loosen. 2.Check if the Rotor is align with Crankshaft position sensor during the crankshaft running.
3	P1120	Throttle position sensor setting value problem	2	1.Make sure if the connector of Throttle position sensor is connected correctly. 2.Check if the Throttle position sensor is adjusted.
4	P1121	Throttle position sensor output range problem	2	1.Make sure if the connector of Throttle position sensor is connected correctly. 2.Check if the Throttle position sensor is adjusted.



Blinks	Failure Codes	Fault description	Priority	Fault management
5	P1122	Throttle position sensor movement speed problem	2	1.Make sure if the connector of Throttle position sensor is connected correctly. 2.Check if the Throttle position sensor is adjusted.
6	P0560	Battery voltage malfunction	1	1. Check if the battery voltage is lower or higher. 2.Check if the charge system is malfunction.
7	P0110	Intake air temperature circuit malfunction	2	Inlet air temperature sensor or electric circuit malfunction
8	P0410	Idle air valve circuit malfunction	2	1. Check if the connector of Idle air valve is loosen. 2.Check if the resistance of valve is normal.
9	P0505	Idle speed volume control range problem	3	Check if the ISC steps range over 65steps.
10	P0251	Injector or electric circuit problem	2	1.Check if the connector of Injector is loosen. 2.Check if the ECU send signal to Injector. 3.Check if the power source and resistance of Injector are malfunction.



Blinks	Failure Codes	Fault description	Priority	Fault management
11	P0350	Ignition coil or electric circuit malfunction	2	1. Check if the connector of ignition coil is loosen. 2. Check if the ECU send signal to Ignition coil. 3. Check if the power source and resistance is malfunction
12	P0230	Fuel pump relay or electric circuit malfunction	2	1. Check if the connector of relay is loosen. 2. Check if the ECU signals to relay. 3. Check the fuel pump relay resistance
13	P0219	Engine speed is over than top speed	2	Check if the belt of CVT is broken.
14	P1560	Sensor don't receive power source from ECU	2	1. Check if ECU output DC5V to sensor. 2. Check if the power source of all sensor is DC5V. 3. Replace a new ECU if the CELP still blinks even the output power source of ECU is normal.
15	P0700	Engine starting speed exceed CVT speed limited	2	No used
16	P0115	Engine temperature sensor or electric circuit malfunction	2	1. Check if the connector of sensor is loosen. 2. Check if ECU pin is broken. 3. Check if the resistance of sensor is malfunction.
17	P1561	Temperature gauge electric circuit malfunction	2	No used



Blinks	Failure Codes	Fault description	Priority	Fault management
18	P0650	CELP electric circuit malfunction	3	<ol style="list-style-type: none"> 1. Check if the lamp of CELP is broken. 2. Check if wires of CELP is broken.
21	P0105	Atmospheric Pressure Sensor/Circuit Malfunction	2	<ol style="list-style-type: none"> 1. Check if the connector of sensor is loosen. 2. Check if ECU pin is broken. 3. Check if voltage of sensor is fit in specification.
22	P0110	Roll sensor or electric circuit malfunction	2	<ol style="list-style-type: none"> 1. Check if the sensor installation direction is correct. 2. Check if voltage of sensor is fit in specification. 3. Check if ECU pin is broken.



SELF-DIAGNOSTIC PROCEDURE

1. Connect the Fi Diagnostic tool with **CAN linker**
2. The power is from vehicle's Battery
3. Updating the software to be **V1.0.7A**



CAN LINKER



Diagnostic Tool Connector (MXU 500i)





Diagnostic Tool Connector(UXV 500i)



FI DIAGNOSTIC TOOL

This tool is developed by KYMCO and for KYMCO vehicle only.

Please refer to the specification when serving this vehicle.

This tool is without battery inside. The power is provided from vehicle.

This software can be updated with the USB cable through internet for new model. The power required of tool is connected with 12V battery.

For connection, connect this tool with the connector of ECU when the ignition switch is ON.

The tool's function includes **ECU version, model name, data analysis** .

- ECU version: includes model name, ECU number, identifications number and software version.
- Failure codes: DTC reading, DTC clearing and troubleshooting.
- Data analysis: For ECU's software inspection.
- Adjust : The adjust function setting is not allowed





ECU VERSION



Press ENTER button

ECU version:

Including of model name, ECU number, identifications number and software version.



MXU 500iRS

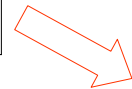

UXV 500 i



DTC INSPECT

1. DTC inspecting



2. DTC loading



3. DTC active

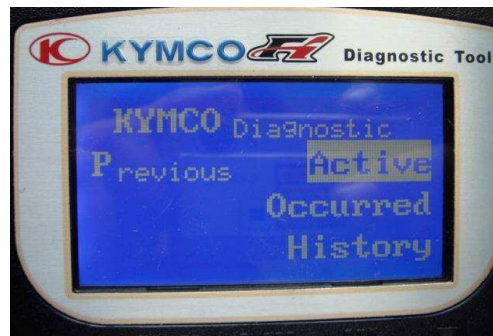

4. DTC display: No. 12



5. Press the “UP” button



6. DTC loading



7. DTC occurred

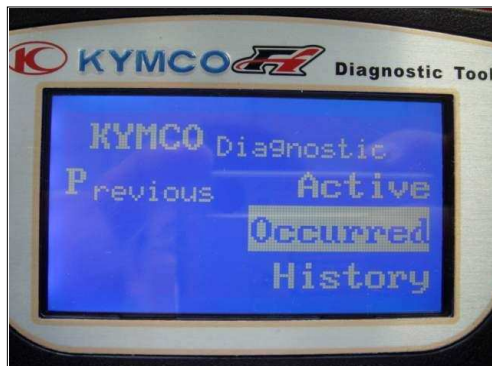

8. DTC display: No. 12



9. Press the “UP” button



10. DTC loading



11. DTC History

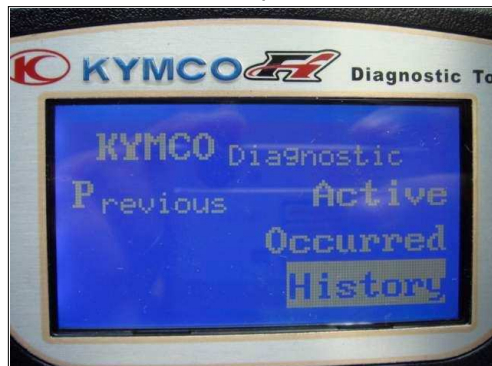

12. DTC display: No 12,18,22



13. Press the “UP” button



14. DTC loading



15. DTC clearing



16. DTC clearing completed



DATA ANALYSIS

Page 01

The measure figures including of Engine speed, Battery voltage and Engine speed.



Page 02

The measure figures including of TPS position, TPI idle adapted and ISC step.



Page 03

The measure figures including of engine temperature ,air temperature and intake pressure . .



Page 04

The measure figures including of atmosphere temperature, fuel injector interval and ignition advance .



Page 05

The measure figures including of gear position and gear ratio.



Page 06

The measure figures including of rollover voltage(The function setting is not allowed).



Page 07

The measure figures including of ECU counter.



IMPORTANT NOTICE

Before maintaining the injection vehicles, you have to notice something as follows,

1. **Never** to dismantle the wire of battery connector while engine is running, or the ECU will be destroyed.
2. **Never** dismantle the ECU while engine is running, or the ECU will be destroyed.
3. **Be sure** to use the anti-interfere spark plug.
4. **Be sure** to relieve the fuel pressure before removing fuel pump or fuel hose.



SPECIFICATIONS

ITEM		SPECIFICATIONS
Throttle body identification number		PTA1
Idle speed		1400±100 rpm
Throttle grip free play		2~6 mm (1/16~1/4 in)
Fuel injector resistance (at 20°C/68°F)		10.6~15.9 Ω
Fuel pump resistance (at 20°C/68°F)	Float at full position	About 101 Ω
	Float at empty position	About 3 Ω
Fuel pump standard pressure (at 80 L/Hr)		300±10 kPa (3 Bar)
Water temperature sensor resistance	At -20°C/-4°F	28.6 KΩ
	At 40°C/104°F/20°C	1.46 KΩ/3.51 KΩ±10%
	At 100°C/212°F	0.176 KΩ
T-MAP sensor resistance(20°C)		1613~2544 Ω (1.2 pin)
Inductive ignition coil		Primary: 0.55~0.75 Ω
Throttle position sensor (TPS) resistance (at 20°C/68°F)		3500~6500 Ω (1.2 pin)
Crank position sensor resistance		96~144 Ω
Roll sensor voltage	Standard	0.4~1.4 V
	Over 65° (fall down)	3.7~4.4 V

Model used : Maxxer 450i / MXU 500i / UXV 500i



ELECTRIC CONTROL UNIT (ECU)

REMOVAL

Disconnect the ECU connector and remove the ECU from the frame. Installation is in the reverse order of the removal.

ECU connector remove procedure (Same as Downtown 125i / People GT 125i)

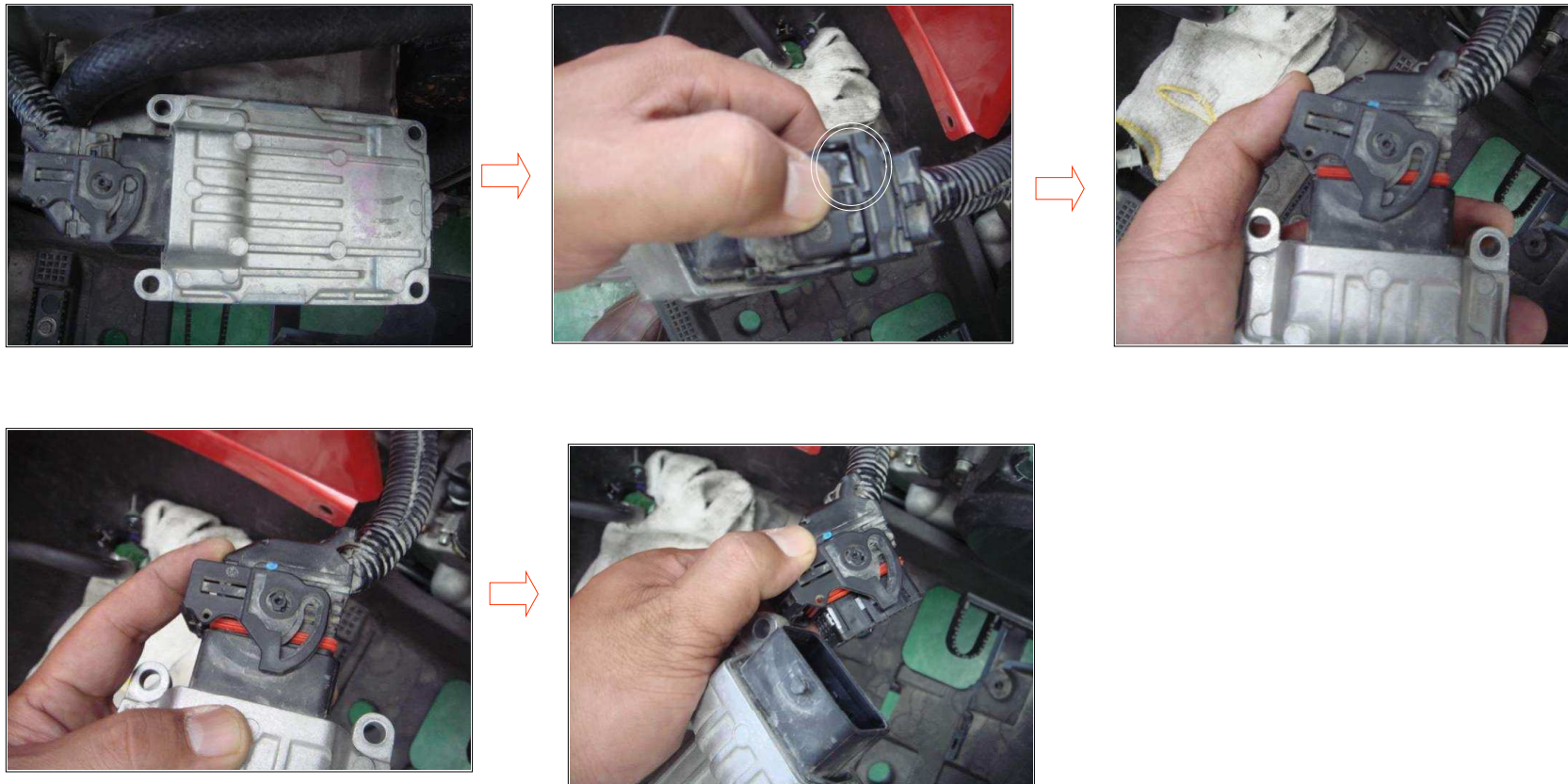

INSTALLATION

ECU connector install procedure (Same as Downtown 125i / People GT 125i)

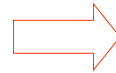

OUTLOOK INSPECTION

1. Check the ECU's pin(1-48) if has any damage.
2. Check the ECU's part number if is correct.
 - 3920A-LGC7-E00 (Maxxer 450i)
 - 3920A-LKA8-E00 (MXU 500i)
 - 3920A-LKC3-E00 (UXV500i)

VOLTAGE INSPECTION

Pin No.	Wire color	Electrical meter	
		(+) probe	(-) probe
B4	R/W		
M3	G/B		

Standard voltage: 12V

Model No.	Model Name
LGC7	Maxxer 450i
LKA8	MXU 500i
LKC3	UXV 500i

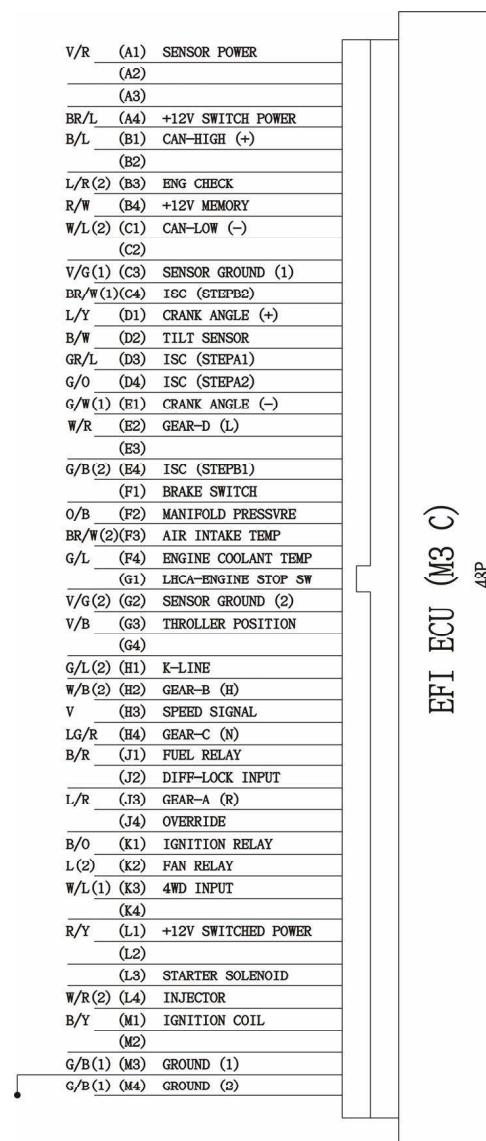

T-MAP (Manifold Air Temperature Pressure) Sensor

RESISTANCE: Pin1 &2

Standard (20 °C) : 1613 ~ 2544 Ω

VOLTAGE : V/R (+) -V/G (-)

Standard : 5V

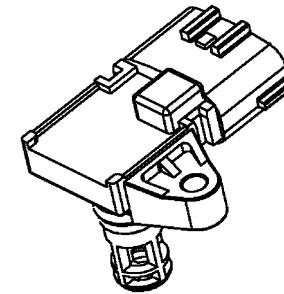

Attention: Don't damage the O-ring.



ISC (Idle Speed Control Motor)

ISC STEP

Start the engine till engine temperature 80°C at idle.

Enter page 02 , then close the throttle fully, Check "ISC STEP"

Standard : lower than 65

Trouble:

engine stop, hard to starting or rough idling speed.



Attention: Don't damage the O-ring.



TPS (Throttle Position Sensor)

RESISTANCE: Pin1 &2

Standard (20 °C /68 °F): 3500~6500 Ω

VOLTAGE : V/R (+) -V/G (-)

Standard : 5V

Enter page 02

Throttle position	Opening angle	Standard
Close	0%	0.67 ± 0.05 V
Open	< 56%	1.8~2.3V



WTS (Water Temperature Sensor)

REMOVAL

Drain the coolant from the cooling system.

Disconnect the WTS sensor connector.

Remove the WTS sensor and O-ring. Be careful not to damage the O-ring.

RESISTANCE

Measure the resistance at the WTS sensor terminals.

°C	-20	40
KΩ	28.6	1.46

Standard: $3.51 \pm 10\%$ KΩ (at 20°C/68°F)

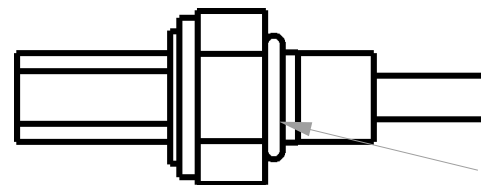
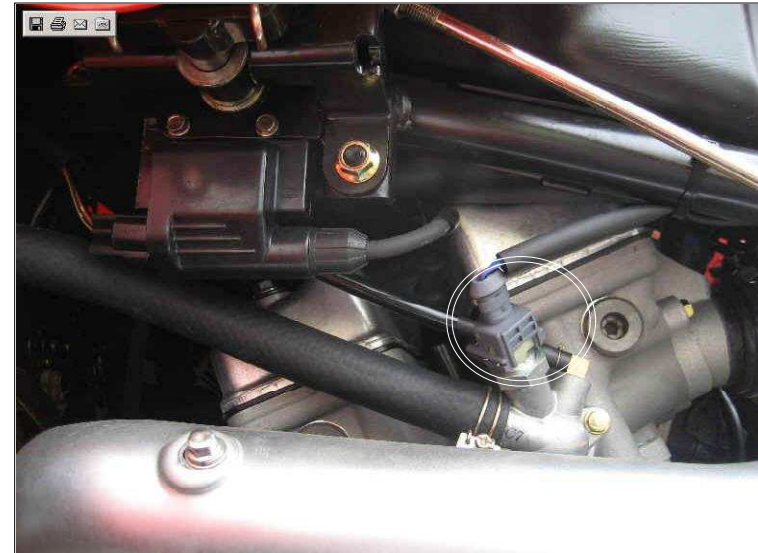

INDUCTIVE IGNITION COIL

RESISTANCE

Primary: 0.55 ~ 0.75 Ω (at 20°C/68°F)



Start the engine till engine temperature 80° C at idle.

Enter page 04 , then close the throttle,

Standard: 12° ~ 16°



INJECTOR

RESISTANCE

Standard (20 °C /68 ° F): 10.6~15.9 Ω

*

Make sure of the fuel pipe without any pressure and then remove the fuel injector.

- Disconnect the fuel pump relay or fuel pump connector.
- Turn the ignition switch to the "ON" position. Starting the engine till the engine stop working.

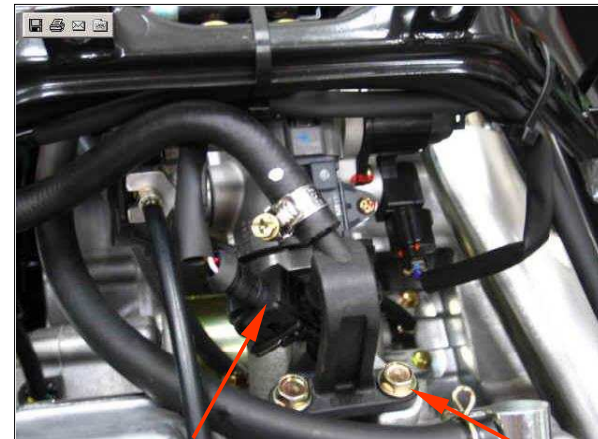

Connector

Bolt



INSTALLATION

Apply the engine oil to a new O-ring.
Install the fuel injector into the fuel pipe.
Ensure the clip of the fuel injector
inserted into the groove of the fuel pipe.
Install the fuel pipe into the intake
manifold .
Be careful not to damage the O-ring.
Tighten the fuel pipe mounting bolts.



Clip



O-ring



FUEL PUMP

Power: DC 8~16V

Output pressure: 3.0 bar

Screws <MXU 500i>

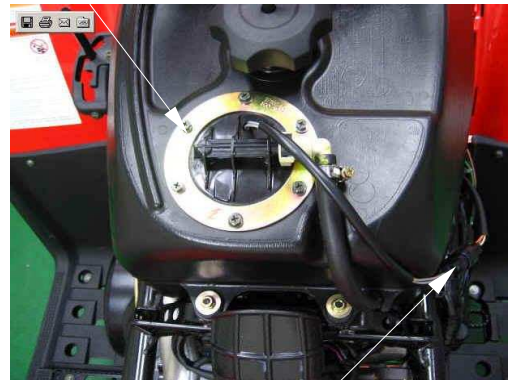

Fuel Pump Connector

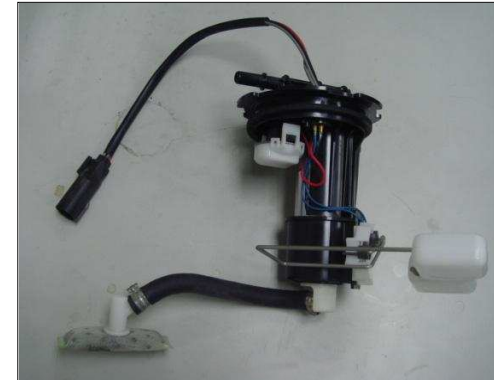

Screws <UXV 500i>

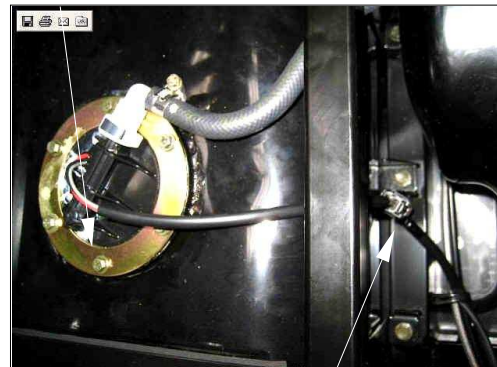

Fuel Pump Connector



RESISTANCE :

Orange/Red(+) & Black(-)

Standard (20 °C /68 ° F):

Fuel Level	F	E
Resistance	101 Ω	3 Ω

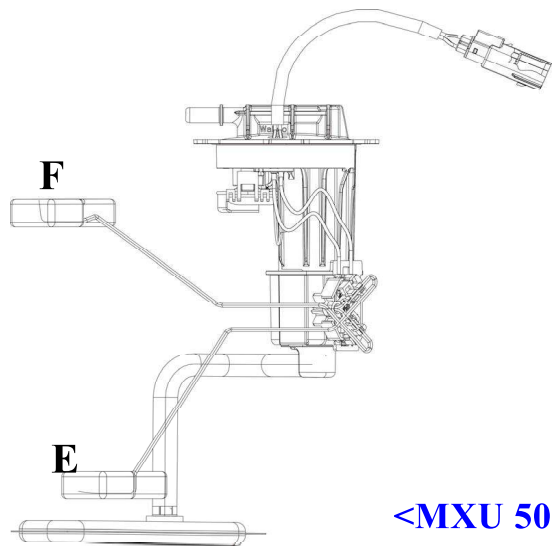
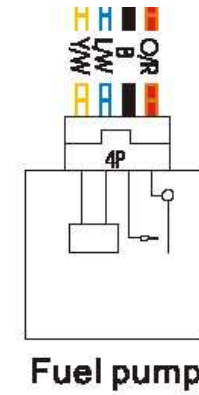

<MXU 500i>

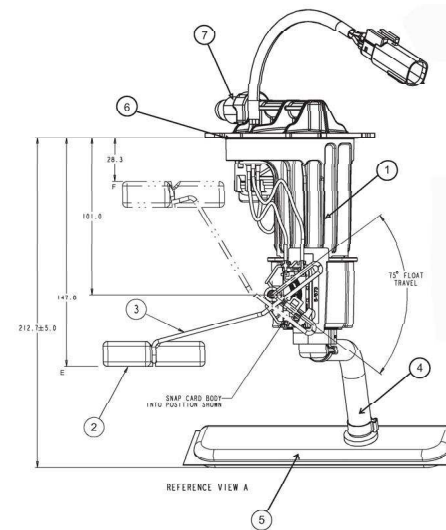

<Maxxer 450i>



THROTTLE BODY

limited speed



add a stop stay

Unlimited speed





KYMCO