

# ENGINE 125 WR LC

Engine workshop manual



1.1 ENQUIRY NOTES	6
1.2 UPDATING GUIDE	6
1.3 WRITING SIMBOLOGY	7
1.4 OPERATIVE SIMBOLOGY	8
1.5 WORK GENERAL RULES	9
1.6 RECOMMENDATIONS	10
1.7 SPARK PLUGS	12
1.8 SPARK PLUG MAINTENANCE	13
1.9 SPARK PLUG REPLACEMENT AT 5000 Km	13
1.10 MOTOR REMOVAL	13
1.11 MOTOR DISASSEMBLY	13
ENGINE SPECIFICATIONS	15
ELECTRICAL SPECIFICATIONS	22
TIGHTENING TORQUES	26
LUBRICATION POINTS AND LUBRICANT TYPES	27
LUBRICATION SYSTEM CHART AND DIAGRAMS	29
PERIODIC MAINTENANCE	32
ADJUSTING THE VALVE CLEARANCE	33
CHECKING THE IGNITION TIMING	37
MEASURING THE COMPRESSION PRESSURE	38
CHECKING THE ENGINE OIL LEVEL	40
CHANGING THE ENGINE OIL	41
ADJUSTING THE CLUTCH CABLE FREE PLAY	43
THERMOSTAT	44
CHECKING THE THERMOSTAT	45
INSTALLING THE THERMOSTAT	46
WATER PUMP	47
DISASSEMBLING THE WATER PUMP	49
CHECKING THE WATER PUMP	49
ASSEMBLING THE WATER PUMP	49
INSTALLING THE WATER PUMP	51

CYLINDER HEAD	52
REMOVING THE CYLINDER HEAD	54
CHECKING THE CYLINDER HEAD	55
CHECKING THE CAMSHAFT SPROCKET AND TIMING CHAIN GUIDE	56
CHECKING THE TIMING CHAIN TENSIONER	56
CHECKING THE DECOMPRESSION SYSTEM	57
INSTALLING THE CYLINDER HEA	57
CAMSHAF	60
CHECKING THE CAMSHAFT	61
CHECKING THE ROCKER ARMS AND ROCKER ARM SHAFTS	61
INSTALLING THE CAMSHAFTAND ROCKER ARMS	62
VALVES AND VALVE SPRINGS	64
REMOVING THE VALVES	65
CHECKING THE VALVES AND VALVE GUIDES	66
CHECKING THE VALVE SEATS	69
CHECKING THE VALVE SPRINGS	70
INSTALLING THE VALVES	72
CYLINDER AND PISTON	74
REMOVING THE PISTON	75
CHECKING THE CYLINDER AND PISTON	76
CHECKING THE PISTON RINGS	77
CHECKING THE PISTON PIN	78
INSTALLING THE PISTON AND CYLINDER	79
GENERATOR AND STARTER CLUTCH	81
REMOVING THE GENERATOR	83
REMOVING THE STARTER CLUTCH	84
CHECKING THE STARTER CLUTCH	84
INSTALLING THE STARTER CLUTCH	85
INSTALLING THE GENERATOR	85
ELECTRIC STARTER	87
CHECKING THE STARTER MOTOR	89

ASSEMBLING THE STARTER MOTOR	90
CLUTCH	91
REMOVING THE CLUTCH	95
CHECKING THE FRICTION PLATES	95
CHECKING THE CLUTCH PLATES	96
CHECKING THE CLUTCH SPRINGS	97
CHECKING THE CLUTCH HOUSING	97
CHECKING THE CLUTCH BOSS	97
CHECKING THE PRESSURE PLATE	98
CHECKING THE CLUTCH PUSH LEVER AND SHORT CLUTCH PUSH ROD	98
CHECKING THE PRIMARY DRIVE GEAR	98
CHECKING THE PRIMARY DRIVEN GEAR	98
INSTALLING THE CLUTCH	99
OIL PUMP	102
CHECKING THE OIL PUMP	104
ASSEMBLING THE OIL PUMP	105
INSTALLING THE OIL PUMP	105
SHIFT SHAFT	106
CHECKING THE SHIFT SHAFI	107
CHECKING THE STOPPER LEVER	107
INSTALLING THE SHIFI SHAFI	107
BALANCER GEAR	108
REMOVING THE PRIMARY DRIVE GEAR AND BALANCER GEARS	109
CHECKING THE BALANCER GEARS AND PRIMARY DRIVE GEAR	109
INSTALLING THE PRIMARY DRIVE GEAR AND BALANCER GEARS	109
CRANKCASE	111
SEPARATING THE CRANKCASE	114
CHECKING THE CRANKCASE	114
CHECKING THE TIMING CHAIN AND TIMING CHAIN GUIDE	115
CHECKING THE OIL STRAINER	115
CHECKING THE BEARINGS AND OIL SEAL	115

INSTALLING THE BEARING RETAINER	115
ASSEMBLING THE CRANKCASE	116
CRANKSHAFT	117
REMOVING THE CRANKSHAFT	118
CHECKING THE CRANKSHAFT	118
INSTALLING THE CRANKSHAFT	119
TRANSMISSION	120

# *Introduction*

## I.1 ENQUIRY NOTES

The intervention in control, maintenance, repairs, replacement parts, etc. in the whole range of our motor vehicle, means not only the competence and experience of the responsible technicians in this task, in the modern technologies, but also the knowledge of the quick and rational procedures, of the technical characteristics, of the calibrated values, of the torque, that only manufacturer is in a condition to lay down for certain.

The present series of WORKSHOP GUIDES for two-stroke engine, provide the main information for the technicians of the sector (Authorized Dealer, etc...) to operate harmoniously on the modern concepts of "good technique" and "safety at work".

The aim of these guides, is about the standard technical interventions in the whole range of engine (two-stroke engine) for RIEJU motor vehicles in the production phase at the spreading time of these manuals. This information refers to the "ENGINES" of the motor vehicles. Some information has been deliberately omitted, since (according to us) it is an essential part of the basic technical knowledge.

Another possible information, can be deduced from the SPARE PARTS CATALOGUES (of each particular model).

Before reading the motor vehicle manual you are interested in, it is important that you examine the first general pages, where you will find the basic information for a good item enquiry and the general nature technical concepts.

**REMARK:**

*The manual provides you with the essential information for the standard intervention procedures. This information is supplied by the engine manufacturers, so therefore, this frees us to be responsible for any eventual error, omissions, etc. The RIEJU company reserves the right to contribute modifications at any time, without any previous notice. For any request or further information please call to Rieju Technical Assistance Service.*

## I.2 UPDATING GUIDE

- **The updating** will be send (in a reasonable period). Each new CD-ROM will replace the one you have already got.
- **The index** will be updated in case modifications and changes of the pages inside no longer guarantee a rational enquiry of the manual.
- **IMPORTANT!** The series of Workshop Guides has to be considered as a **work tool**, strictly speaking, and it can remain in "value" through time, only if it is constantly updating.



## 1.3 WRITING SIMBOLOGY



**ATTENTION!** Some caution advice and information as regards to the safety of the motorcyclist (vehicle user) and the safeguard of the whole vehicle.



**ATTENTION!** Descriptions relating to some dangerous interventions for the maintenance engineer, the repair technician, the workshop staff or strangers, for the atmosphere, for the vehicle and for the equipments.



**FIRE RISK**  
Operations which could cause fire.



**DANGER OF EXPLOSION**  
Operations which could cause explosion.



**TOXIC**  
Evident danger of poisoning or inflammation of the first respiratory track.



**MECHANICAL MAINTENANCE**  
Operations to be performed only by an expert mechanic.



**ELECTRICAL MAINTENANCE**  
Operations be performed only by an expert electrical / electronic technician.



**NO!**  
Operations which must be avoided.



**ENGINE WOKSHOP GUIDE**  
Information derived from this documentation.



**SPARE PARTS CATALOGUES**  
Information derived from this documentation.



F	Figure
Pr Tr	Torque
P	Page
Ap	Sub-section
S	Section
Es	Diagram
T	Table
Tr	Bolt

**Remark:**

*Illustrations frequently shown fixing or regulator screws, specified with the letter **Tr**. The **number** besides this letter indicates the quantity of identical **Tr** existing in the group or object component of the description and its corresponding illustration. The letter **without number**, indicates **quantity 1**. In case of different screws shown in the same figure, a **number** and a **small letter** will follow the letter **Tr** (example: (Tr4a)).*

*The re-assembly of groups and components is usually carried out in **opposite way** to the disassembly interventions (excepting specified description).*

**I.4 OPERATIVE SIMBOLOGY**

L) Loctite



O) Lubrication (oil)



G) Greasing (grease)





## I.5 WORK GENERAL RULES

• **The following advice, recommendations, and warnings,** guarantee rational interventions in the maximum operative safety, ruling out considerably the probabilities of accidents, all kind of damage and time-out. Therefore, we advise you to observe them scrupulously.

### ADVICE:

- Always use high quality equipments.
- For raising the motor vehicle, use manufactured equipment on purpose and subject the European regulations.
- During the operations, tools must be within arm's reach, as far as possible, according to a predetermined sequence, and anyway, never on the vehicle or in a hiding or inaccessible place.
- Keep your workplace duly clean and tidy.
- To tighten bolts and nuts, begin with those of **bigger diameter** or the interior ones, proceeding in "**cross**" in one go and so on.
- The most proper use of the spanner (the fork one), is **in one go** never pushing.
- The rolling monkey wrench (F-1) have to be used in emergency conditions, this is to say, when the suitable size tool is not available. During the effort, the mobile clamp tend to open and this could damage the bolt as well as lead to obtain a torsion moment of an unreliable tightness. Anyway, use tools like the illustration (figure I).
- Excluding some exceptional assistance cases, prepare a **record card** for the Customers, where all the interventions done and notes for possible controls in future will be entered.

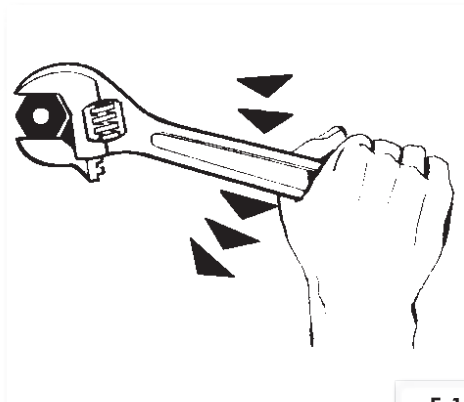

F-1



## 1.6 RECOMMENDATIONS

- **Before beginning** any intervention in the motor vehicle, wait till all and each one of the components of the same vehicle are **completely cool down**.
- If the operations need two technicians work, it is necessary that they previously come to an agreement on tasks and synergies.
- Always check the correct assembly of each component, before assemble another one.
- Lubricate the need spare parts, before re-assembly.
- The linings, the watertight and elastic rings and the pins must be replaced when disassembly takes place.
- The torque values indicated in the manuals, refer to the “**final tight**”, and they have to be progressively reached, in consecutive goes.
- The loosen and tighten operations of the parts in aluminium alloy (sump) must be carried out when the **motor cools down**.
- Always use screwdrivers of suitable size for the bolts in use.
- **Never work in awkward conditions neither in an unstable situation of the motor vehicle.**
- **Never use a lining or an elastic ring again.**
- **Never unscrew or screw down bolts and nuts with clips since, besides it does not exert enough blockade force, the bolt cap or the nut hexagon can be damaged.**
- **Do not hit with the hammer (or another tool) on the spanner to loosen or tighten bolts and nuts (F-2).**
- **Do not use the extension bar for the spanner (F-3).**

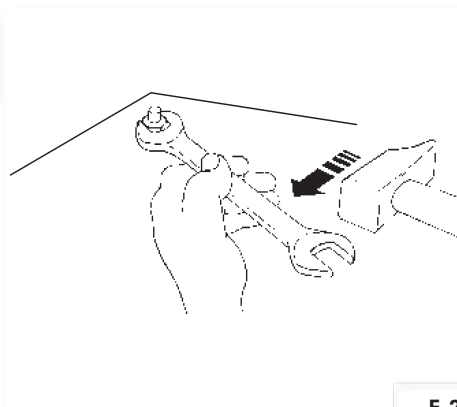

F-2

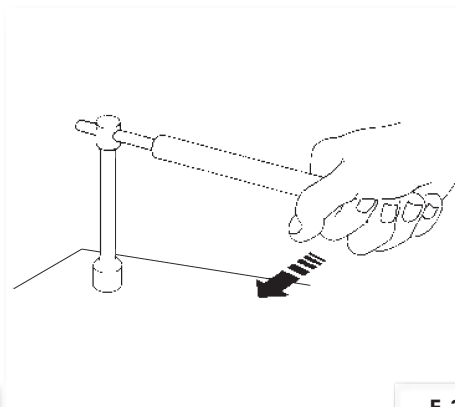

F-3



**Never use, under no circumstances, free flames.**

**Never leave** open and not suitable **containers** with fuel, blocking the pass, near to heat sources, etc.



**Never use fuel** like a cleansing detergent for the motor vehicle or for the workshop floor. The components must be cleaned with a low grade of inflammability detergent.



**Never suck in or blow in the fuel pipe.**

**Never carry out welds** in the presence of fuel. Remove the tank although it is totally empty and disconnected the negative (-) lead of the battery.

**Never leave the motor running in closed premises or without air vent.**



Before each intervention, make sure of the motor vehicle is perfectly steady. The front wheel should be anchored, preferably, to the integrated tool (A/F-4) in the running board .

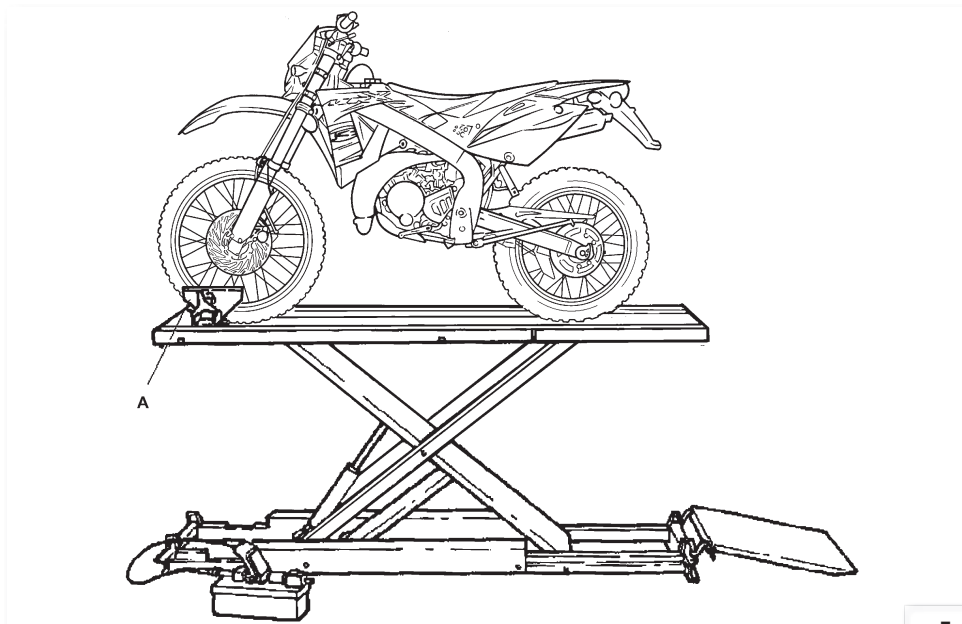

F-4



## I.7 SPARK PLUGS

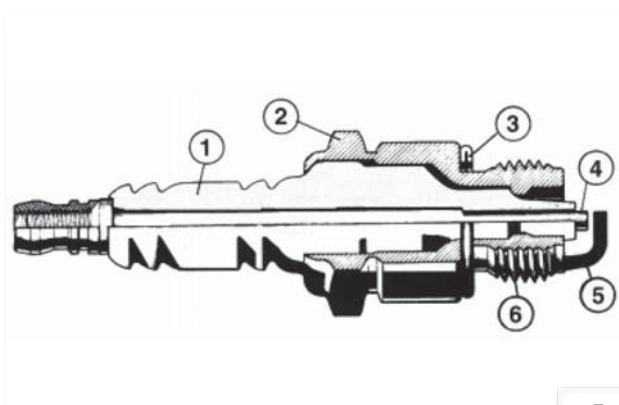

1. Insulator
2. Body
3. Lining
4. Electrode
5. Earth electrode
6. Thread

F-5

### SPARK PLUGS CONTROL AT 1.000 Km

- Do not touch the spark plug if the **motor is hot**.
- The coal tip and the insulator coloration (around the central electrode) provide with useful information about the **thermic degree** of the spark plug, the **carburation**, the **lubrication** and the overall condition of the engine.
- A **light brown** (insulator) coloration indicates the correct general operation.
- Black sooty tips, dry (to the touch), opaque, indicate that the operation temperature is too low (spark plug thermic degree is too high), too rich carburation or faulty ignition.
- Off-white insulator indicates: a mixture too weak or spark plug thermic degree too low (spark plug too hot).
- Verify the distance between the electrodes (F.6) (although the spark plug is new) using a calibrated calibre of thickness, and eventually, register it working only on the earth electrode.

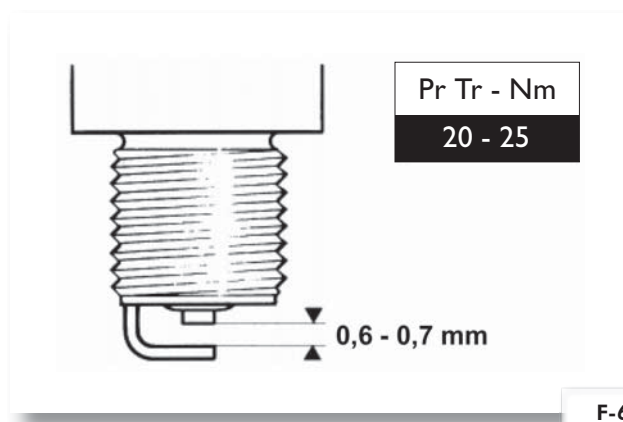

F-6



### I.8 SPARK PLUG MAINTENANCE

- The spark plug maintenance consists in removing it periodically from the motor to check (visually) the conditions and the distance between the electrodes.
- Proceed to clean the electrodes and the insulator carefully, using a wire brush.
- Eliminate possible waste with a strong jet of compressed air.
- Lubricate the thread of the spark plug with motor oil or grease, that conducts electricity, then screw it by hand until the bottom.  
Then press it moderately with the respective spanner (see torque in F.6).



**It is necessary to replace all spark plug with fissures in the insulator or corroded electrodes.**

### I.9 SPARK PLUG REPLACEMENT AT 5000 Km

- At the foreseen kilometres, replace always the spark plug with a new one, choosing one of those that the Company RIEJU, S.A. recommends.
- When the discharged spark plug is being eliminated, inspect always its general look (as previously stated) to check the good state of the engine.

### I.10 MOTOR REMOVAL

- To remove the motor from the frame, look up in the Workshop Guide, in “Cyclist” section, where you will find all the steps to follow.

### I.11 MOTOR DISASSEMBLY

**The manufacturer is exempt from any responsibility caused by damages of any nature in a disassembly and a new assembly of the engine and each of its parts, owing to the use of unsuitable tools for this kind of interventions.**



**Exclusively use ORIGINAL RIEJU SPARE PARTS.**

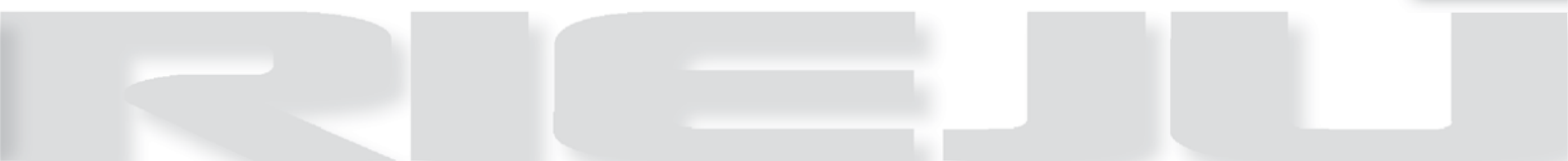





### ENGINE SPECIFICATIONS

ELEMENTO	SPECIFICATIONS
<b>ENGINE</b> Engine type Displacement Cylinder arrangement Bore x stroke Compression ratio Standard compression pressure (at sea level)  Minimum-maximum Starting system	<b>Liquid cooled 4-stroke, SOHC</b> 124,7 cm <sup>3</sup> Forward-inclined single cylinder 52,0 x 58,6 mm (2,05 x 2,31") 11,20:1 550 kPa/600 r/min (78,2 psi/600 r/min) (5,5 kgf/cm <sup>2</sup> /600 r/min) 480-620 kPa (68,3 – 88,2 psi) (4,8 - 6,2 kgf/cm <sup>2</sup> ) Electric starter
<b>FUEL</b> Recommended fuel	Premium unleaded gasoline only
<b>ENGINE OIL</b> <b>Lubrication system</b> <b>Type</b>  <b>Recommended engine oil grade</b> <b>Engine oil quantity</b> Total amount Without oil filter element replacement With oil filter element replacement	Wet sump SAE 10W-30, SAE 10W-40, SAE 15W-40, SAE 20W-40 or SAE 20W-50 API service SG type or higher, JASO standard MA  1,15 l (1,22 US qt) (1,01 Imp. qt) 0,95 l (1,00 US qt) (0,84 Imp. qt) 1,00 l (1,06 US qt) (0,88 Imp. qt)
<b>OIL FILTER</b> Oil filter type	Paper
<b>OIL PUMP</b> Oil pump type Inner-rotor-to-outer-rotor-tip clearance Limit Outer-rotor-to-oil-pump-housing clearance Limit Oil-pump-housing-to-inner-and-outer-rotor clearance Limit Relief valve operating pressure Pressure check location	Trochoid Less than 0,15 mm (0,0059") 0,23 mm (0,0091") 0,13 - 0,18 mm (0,0051 – 0,0071") 0,25 mm (0,0098") 0,06 - 0,11 mm (0,0024 – 0,0043")  0,18 mm (0,0071") 39,2 - 78,4 kPa (5,7 - 11,4 psi) (0,39 - 0,78 kgf/cm <sup>2</sup> ) Check bolt on cylinder head body



## ENGINE SPECIFICATIONS

ELEMENT	SPECIFICATIONS
<p><b>THERMOSTAT</b>            Model/manufacturer            Valve opening temperature            Valve full open temperature            Valve lift (full open)</p> <p><b>Radiator core</b>            Width            Height            Depth</p> <p><b>Water pump</b>            Water pump type            Reduction ratio</p>	<p>SYPINIPPON THERMOSTAT            80,5 - 83,5 °C (176,9 – 182,3 °F)            95,0 °C (203,0 °F)            3,0 mm (0,12")</p> <p>198,0 mm (7,80")            128,0 mm (5,04")            24,0 mm (0,94")</p> <p>Single suction centrifugal pump            19/38 (0,500)</p>
<p><b>SPARK PLUG (S)</b>            Manufacturer/model            Spark plug gap</p>	<p>NGK/CR8E            0,7 - 0,8 mm (0,028-0,031")</p>
<p><b>CYLINDER HEAD</b>            Volume            Warpige limit</p>	<p>9,90 - 10,50 cm<sup>3</sup> (0,60-0,64 cu.in)            0,03 mm (0,0012")</p>
<p><b>CAMSHAFT</b>            Drive system            Camshaft lobe dimensions            Intake A            Limit            Intake B            Limit            Exhaust A            Limit            Exhaust B            Limit            Camshaft runout limit</p>	<p>Chain drive (left)</p> <p>30,225 - 30,325 mm (1,1900-1,1939in)            30,125 mm (1,1860in)            25.114 - 25.214 mm            25.014 mm            30.261 - 30.361 mm            30.161 mm            25.172 - 25.272 mm            25.072 mm            0,030 mm (0,0012in)</p>
<p><b>TIMING CHAIN</b>            Modellnumber of links            Tensioning system</p>	<p>DID SCR-0404SV/96            Automatic</p>

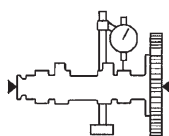
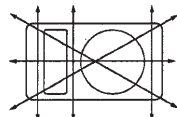

### ENGINE SPECIFICATIONS

ELEMENT	SPECIFICATIONS
<p><b>ROCKER ARM/ROCKER ARM SHAFT</b></p> <p>Rocker arm inside diameter</p> <p>Limit</p> <p>Rocker arm shaft outside diameter</p> <p>Limit</p> <p>Rocker-arm-to-rocker-arm-shaft clearance</p> <p>Limit</p>	<p>9,985 - 10,000 mm (0,3931-0,3937")</p> <p>10,015 mm (0,3943")</p> <p>9,966 - 9,976 mm (0,3924-0,3928")</p> <p>9,941 mm (0,3914")</p> <p>0,009 - 0,034 mm (0,0004-0,0013")</p> <p>0,074 mm (0,0029")</p>
<p><b>VALVE, VALVE SEAT, VALVE GUIDE</b></p> <p><b>VALVE CLEARANCE (COLD)</b></p> <p>Intake</p> <p>Exhaust</p> <p><b>Valve dimensions</b></p> <p>Valve head diameter A (intake)</p> <p>Valve head diameter A (exhaust)</p> <p>Valve face width B (intake)</p> <p>Valve face width B (exhaust)</p> <p>Valve seat width C (intake)</p> <p>Limit</p> <p>Valve seat width C (exhaust)</p> <p>Limit</p> <p>Valve margin thickness D (intake)</p> <p>Valve margin thickness D (exhaust)</p> <p>Valve stem diameter (intake)</p> <p>Limit</p> <p>Valve stem diameter (exhaust)</p> <p>Limit</p> <p>Valve guide inside diameter (intake)</p> <p>Limit</p> <p>Valve guide inside diameter (exhaust)</p>	<p>0,10 - 0,14 mm (0,0039-0,0055")</p> <p>0,20 - 0,24 mm (0,0079-0,0094")</p> <p>19,40 - 19,60 mm (0,7638-0,7717")</p> <p>16,90 - 17,10 mm (0,6654-0,6732")</p> <p>1,538 - 2,138 mm (0,0606-0,0842")</p> <p>1,538 - 2,138 mm (0,0606-0,0842")</p> <p>0,90 - 1,10 mm (0,0354-0,0433")</p> <p>1,6 mm (0,06")</p> <p>0,90 - 1,10 mm (0,0354-0,0433")</p> <p>1,6 mm (0,06")</p> <p>0,50 - 0,90 mm (0,0197-0,0354")</p> <p>0,50 - 0,90 mm (0,0197-0,0354")</p> <p>4,475 - 4,490 mm (0,1762-0,1768")</p> <p>4,445 mm (0,1750")</p> <p>4,460 - 4,475 mm (0,1756-0,1762")</p> <p>4,430 mm (0,1744")</p> <p>4,500 - 4,512 mm (0,1772-0,1776")</p> <p>4,550 mm (0,1791")</p> <p>4,500 - 4,512 mm (0,1772-0,1776")</p>

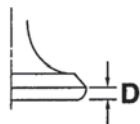
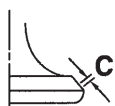

## ENGINE SPECIFICATIONS

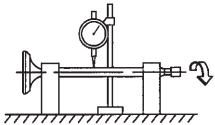
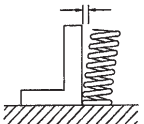
ELEMENT	SPECIFICATIONS
<p><b>VALVE, VALVE SEAT, VALVE GUIDE</b></p> <p>Limit Valve-stem-to-valve-guide clearance (intake) Limit Valve-stem-to-valve-guide clearance (exhaust) Limit Valve stem runout</p>  <p>Cylinder head valve seat width (intake) Limit Cylinder head valve seat width (exhaust) Limit</p>	<p>4,550 mm (0,1791") 0,010 - 0,037 mm (0,0004-0,0015") 0,080 mm (0,0032") 0,025 - 0,052 mm (0,0010-0,0020") 0,100 mm (0,0039") 0,010 mm (0,0004")</p> <p>0,90 - 1,10 mm (0,0354-0,0433") 1,6 mm (0,06") 0,90 - 1,10 mm (0,0354-0,0433") 1,6 mm (0,06")</p>
<p><b>VALVE SPRING</b></p> <p>Free length (intake) Limit Free length (exhaust) Limit Installed length (intake) Installed length (exhaust) Spring rate K1 (intake) Spring rate K2 (intake) Spring rate K1 (exhaust) Spring rate K2 (exhaust) Installed compression spring force (intake) Installed compression spring force (exhaust) Spring tilt (intake) Spring tilt (exhaust)</p>  <p>Winding direction (intake) Winding direction (exhaust)</p>	<p>41,71 mm (1,64") 39,62 mm (1,56") 41,71 mm (1,64") 39,62 mm (1,56") 35,30 mm (1,39") 35,30 mm (1,39") 23,54 N/mm (134.41 lb/") (2.40 kgf/mm) 36,58 N/mm (208.87 lb/") (3.73 kgf/mm) 23,54 N/mm (134.41 lb/") (2.40 kgf/mm) 36,58 N/mm (208.87 lb/") (3.73 kgf/mm) 140 - 162 N (31,47 - 36,42 lbf) (14,28 - 16,52 kgf) 140 - 162 N (31,47 - 36,42 lbf) (14,28 - 16,52 kgf) 2,5°/1,8 mm 2,5°/1,8 mm</p> <p>Clockwise Clockwise</p>
<p><b>CYLINDER</b></p> <p>Bore Wear limit Taper limit Out of round limit</p>	<p>52,000 - 52,010 mm (2,0472-2,0476") 52,110 mm (2,0516") 0,050 mm (0,0020") 0,005 mm (0,0002")</p>

### ENGINE SPECIFICATIONS

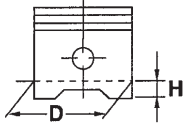
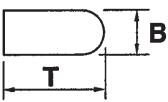
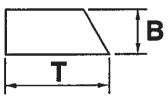
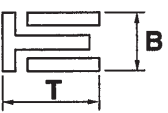
ELEMENT	SPECIFICATIONS
<p><b>PISTON</b></p> <p>Piston-to-cylinder clearance Limit Diameter D Height H</p>  <p>Offset Offset direction Piston pin bore inside diameter Limit Piston pin outside diameter Limit Piston-pin-to-piston-pin-bore clearance Limit</p>	<p>0,015 - 0,048 mm (0,0006-0,0019") 0,15 mm (0,0059") 51,962 - 51,985 mm (2,0457-2,0466") 5,0 mm (0,20")</p> <p>0,50 mm (0,0197") Intake side 14,002 - 14,013 mm (0,5513-0,5517") 14,043 mm (0,5529") 13,995 - 14,000 mm (0,5510-0,5512") 13,975 mm (0,5502") 0,002 - 0,018 mm (0,0001-0,0007") 0,068 mm (0,0027")</p>
<p><b>PISTON RING</b></p> <p><b>Top ring</b> Ring type Dimensions (B x T)</p>  <p>End gap (installed) Limit Ring side clearance Limit</p> <p><b>2nd ring</b> Ring type Dimensions (B x T)</p>  <p>End gap (installed) Limit Ring side clearance Limit</p> <p><b>Oil ring</b> Dimensions (B x T)</p>  <p>End gap (installed) Ring side clearance</p>	<p>Barrel 0,80 x 1,90 mm (0,03 x 0,07")</p> <p>0,10 - 0,25 mm (0,0039-0,0098") 0,50 mm (0,0197") 0,030 - 0,065 mm (0,0012-0,0026") 0,100 mm (0,0039")</p> <p>Taper 0,80 x 2,10 mm (0,03 x 0,08")</p> <p>0,10 - 0,25 mm (0,0039-0,0098") 0,60 mm (0,0236") 0,020 - 0,055 mm (0,0008-0,0022") 0,100 mm (0,0039")</p> <p>1,50 x 1,95 mm (0,06 x 0,08")</p> <p>0,20 - 0,70 mm (0,0079-0,0276") 0,040 - 0,160 mm (0,0016-0,0063")</p>

## ENGINE SPECIFICATIONS

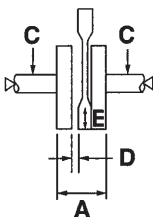
ELEMENT	SPECIFICATIONS
<p><b>CRANKSHAFT</b></p> <p>Width A Runout limit C Big end side clearance D Big end radial clearance E</p> 	<p>47,95 - 8,00 mm (1,888-1,890") 0,030 mm (0,0012") 0,110 - 0,410 mm (0,0043-0,0161") 0,004 - 0,014 mm (0,0002-0,0006")</p>
<p><b>BALANCER</b></p> <p>Balancer drive method</p>	<p>Gear</p>
<p><b>CLUTCH</b></p> <p>Clutch type Clutch release method Clutch lever free play Friction plate 1 thickness Wear limit Plate quantity Friction plate 3 thickness Wear limit Plate quantity Friction plate 2 thickness Wear limit Plate quantity Clutch plate thickness Plate quantity Warping limit Clutch spring free length Minimum length Spring quantity Push rod bending limit</p>	<p>Wet, multiple-disc Inner push, cam push 10,0 - 15,0 mm (0,39-0,59") 2,90 - 3,10 mm (0,114-0,122") 2,80 mm (0,1102") 1 2,90 - 3,10 mm (0,114-0,122") 2,80 mm (0,1102") 3 2,90 - 3,10 mm (0,114-0,122") 2,80 mm (0,1102") 1 1,45 - 1,75 mm (0,057-0,069") 4 0,20 mm (0,0079") 38,71 mm (1,52") 36,77 mm (1,45") 4 pcs 0,500 mm (0,0197")</p>
<p><b>TRANSMISSION</b></p> <p>Transmission type Primary reduction system Primary reduction ratio Secondary reduction system Secondary reduction ratio Operation</p>	<p>Constant mesh 6-speed Helical gear 73/24 (3,042) Chain drive 48/14(3,429) Left foot operation</p>

### ENGINE SPECIFICATIONS

ELEMENT	SPECIFICATIONS
<b>TRANSMISSION</b>	
Gear ratio	
1 <sup>st</sup>	34/12 (2,833)
2 <sup>nd</sup>	30/16 (1,875)
3 <sup>rd</sup>	30/22 (1,364)
4 <sup>th</sup>	24/21 (1,143)
5 <sup>th</sup>	22/23 (0,957)
6 <sup>th</sup>	21/25 (0,840)
Main axle runout limit	0,08 mm (0,0032")
Drive axle runout limit	0,08 mm (0,0032")
<b>SHIFTING MECHANISM</b>	
Shift mechanism type	Shift drum and guide bar
Shift fork thickness	5,76 - 5,89 mm (0,227 – 0,232") × 1
Shift fork thickness	4,76 - 4,89 mm (0,187 – 0,193") × 2

**ELECTRICAL SPECIFICATIONS**

<b>ELEMENT</b>	<b>SPECIFICATIONS</b>
<b>VOLTAGE</b> System voltage	12V
<b>IGNITION SYSTEM</b> Ignition system Ignition timing (B.T.D.C.)	TCI (digital) 5,0°/1.400 r/min
<b>IGNITION COIL</b> Model/manufacturer Primary coil resistance Secondary coil resistance	2JN/YAMAHA 1,92 - 2,88 $\Omega$ at 20° 6,32 - 9,48 $\Omega$ at 20°
<b>AC MAGNETO</b> Model/manufacturer Standard output Standard output Stator coil resistance	F39S/YAMAHA 14,0V, 20,8 A 5.000 r/min 14,0V, 235 W 5.000 r/min 0,32 - 0,48 $\Omega$ a 20 °C (68 °F)
<b>RECTIFIER REGULATOR</b> Regulator type Model/manufacturer Regulated voltage (DC) Rectifier capacity (DC) Withstand voltage	Semi conductor-short circuit SH640EA/SHINDENGEN 14,1 - 14,9 V 25,0 A 200,0 V
<b>ELECTRIC STARTING SYSTEM</b> System type	Constant mesh
<b>STARTER MOTOR</b> Model/manufacturer Power output Armature coil resistance Brush overall length Limit Brush spring force Commutator diameter Limit Mica undercut (depth)	3CI/YAMAHA 0,20 kW 0,0315 - 0,0385 $\Omega$ 7,0 mm (0,28") 3,50 mm (0,14") 3,92 - 5,88 N (14,11 - 21,17 oz) (400 - 600 gf) 17,6 mm (0,69") 16,6 mm (0,65") 1,35 mm (0,05")



### 2.1 GENERAL TIGHTENING TORQUE SPECIFICATIONS

• This chart specifies tightening torques for standard fasteners with a standard ISO thread pitch.

Tightening torque specifications for special components or assemblies are provided for each chapter of this manual.

To avoid warpage, tighten multi-fastener assemblies in a crisscross pattern and progressive stages until the specified tightening torque is reached. Unless otherwise specified, tightening torque specifications require clean, dry threads. Components should be at room temperature.

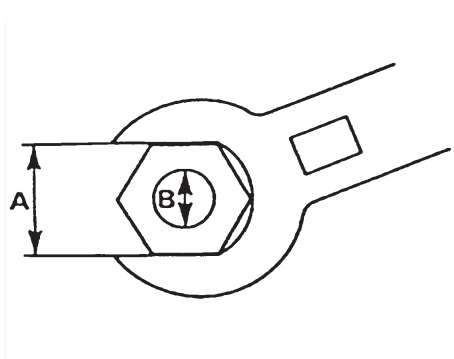

**A**= Distance between flats





**B**= Outside thread diameter

A (Nut)	B (Bolt)	General tightening torque		
		N.m	Kgf.m	ft.lb
10mm	6mm	6	0,6	4,3
12mm	8mm	15	1,5	11
14mm	10mm	30	3,0	22
17mm	12mm	55	5,5	40
19mm	14mm	85	8,5	61
22mm	16mm	130	13,0	94







# Engine tightening torques

## Engine

ELEMENT	THREAD SIZE	Q'TY	TIGHTENING TORQUE	REMARKS
Cylinder head bolt	M8	4	22 Nm (2,2 m-kg, 16 ft-lb)	
Cylinder head bolt	M6	2	10 Nm (1,0 m-kg, 7,2 ft-lb)	
Spark plug	M10	1	13 Nm (1,3 m-kg, 9,4 ft-lb)	
Cylinder head cover bolt	M6	5	10 Nm (1,0 m-kg, 7,2 ft-lb)	
Oil check bolt	M6	1	7 Nm (0,7 m-kg, 5,1 ft-lb)	
Balancer driven gear nut	M10	1	50 Nm (5,0 m-kg, 36 ft-lb)	
Valve adjusting screw locknut	M5	4	7 Nm (0,7 m-kg, 5,1 ft-lb)	
Camshaft sprocket bolt	M8	1	30 Nm (3,0 m-kg, 22 ft-lb)	
Camshaft retainer bolt	M6	2	7 Nm (0,7 m-kg, 5,1 ft-lb)	
Timing chain guide (intake side) bolt	M6	1	10 Nm (1,0 m-kg, 7,2 ft-lb)	
Timing chain tensioner bolt	M6	2	10 Nm (1,0 m-kg, 7,2 ft-lb)	Yamaha bond n° 1215 (Three Bond n° 1215®)
Water pump assembly bolt	M6	2	10 Nm (1,0 m-kg, 7,2 ft-lb)	
Water pump assembly bolt	M6	1	10 Nm (1,0 m-kg, 7,2 ft-lb)	
Water pump housing cover bolt	M6	4	10 Nm (1,0 m-kg, 7,2 ft-lb)	
Impeller shaft retainer bolt	M6	2	10 Nm (1,0 m-kg, 7,2 ft-lb)	
Thermostat cover bolt	M6	2	10 Nm (1,0 m-kg, 7,2 ft-lb)	
Oil pump assembly screw	M5	2	4 Nm (0,4 m-kg, 2,9 ft-lb)	
Engine oil drain plug	M35	1	32 Nm (3,2 m-kg, 23 ft-lb)	
Oil fi lter element cover bolt	M6	2	10 Nm (1,0 m-kg, 7,2 ft-lb)	
Oil fi lter element cover bolt	M6	1	10 Nm (1,0 m-kg, 7,2 ft-lb)	
Oil baffl e plate bolt	M6	2	10 Nm (1,0 m-kg, 7,2 ft-lb)	
Intake manifold bolt	M6	2	10 Nm (1,0 m-kg, 7,2 ft-lb)	
Crankcase bolt	M6	2	10 Nm (1,0 m-kg, 7,2 ft-lb)	
Cran kcase bolt	M6	6	10 Nm (1,0 m-kg, 7,2 ft-lb)	
Crankcase bolt	M6	4	10 Nm (1,0 m-kg, 7,2 ft-lb)	
Generator cover bolt	M6	7	10 Nm (1,0 m-kg, 7,2 ft-lb)	
Clutch cover bolt	M6	4	10 Nm (1,0 m-kg, 7,2 ft-lb)	
Clutch cover bolt	M6	6	10 Nm (1,0 m-kg, 7,2 ft-lb)	
Drive sprocket cover bolt	M6	2	10 Nm (1,0 m-kg, 7,2 ft-lb)	
Starter clutch bolt	M6	3	14 Nm (1,4 m-kg, 10 ft-lb)	
Primary drive gear nut	M12	1	60 Nm (6,0 m-kg, 43 ft-lb)	
Clutch spring bolt	M6	4	12 Nm (1,2 m-kg, 8,7 ft-lb)	
Short clutch push rod locknut	M6	1	8 Nm (0,8 m-kg, 5,8 ft-lb)	

# Engine tightening torques

## Engine

ELEMENT	THREAD SIZE	Q'TY	TIGHTENING TORQUE	REMARKS
Clutch boss nut	M14	1	70 Nm (7,0 m-kg, 50 ft-lb)	
Drive sprocket retainer bolt	M6	2	10 Nm (1,0 m-kg, 7,2 ft-lb)	
Crankcase bearing retainer bolt	M6	2	7 Nm (0,7 m-kg, 5,1 ft-lb)	
Shift drum segment screw	M6	1	12 Nm (1,2 m-kg, 8,7 ft-lb)	
Stopper lever bolt	M6	1	10 Nm (1,0 m-kg, 7,2 ft-lb)	
Stator coil bolt	M6	3	10 Nm (1,0 m-kg, 7,2 ft-lb)	
Crankshaft position sensor bolt	M6	2	10 Nm (1,0 m-kg, 7,2 ft-lb)	
Generator rotor nut	M12	1	70 Nm (7,0 m-kg, 50 ft-lb)	
Neutral switch	M10	1	20 Nm (2,0 m-kg, 14 ft-lb)	
Starter motor bolt	M6	1	10 Nm (1,0 m-kg, 7,2 ft-lb)	
Starter motor bolt	M6	1	10 Nm (1,0 m-kg, 7,2 ft-lb)	
Coolant temperature sensor	M12	1	18 Nm (1,8 m-kg, 13 ft-lb)	

**TIGHTENING TORQUES**

Cylinder head tightening sequence:

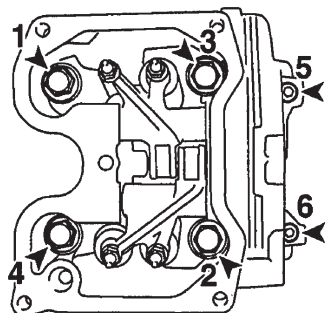

Generator cover tightening sequence:

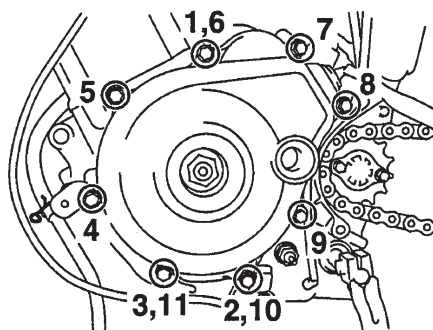

Clutch cover tightening sequence:

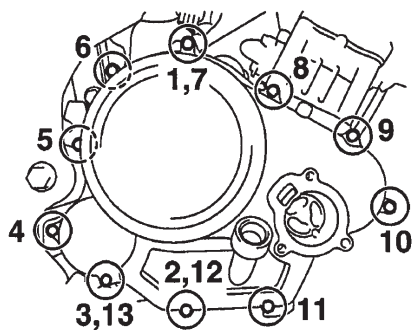



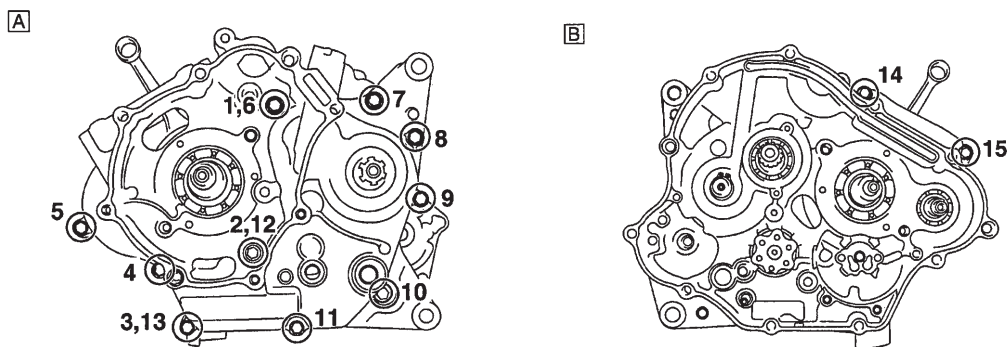





























Crankcase tightening sequence:











A. Left crankcase  
B. Right crankcase



## LUBRICATION POINTS AND LUBRICANT TYPES

LUBRICATION POINT	LUBRICANT
Oil seal lips	
Bearings	
Cylinder head bolt seats, cylinder head bolt threads and washers	
Water pump assembly O-rings	
Cylinder head cover gasket	
Connecting rod big end	
Piston pin	
Cylinder inner surface, piston, ring grooves, and piston rings	
Balancer O-rings	
Camshaft lobes and rocker arm rollers	
Decompression cam	
Valve stems and valve stem seals	
Valve stem ends	
Rocker arm shafts	
Rocker arm inner surface	
Decompression arm pivoting point	
Engine oil drain plug O-ring	
Oil pump driven gear shaft	
Oil filter cover O-ring	
Intake manifold O-ring	
Timing mark accessing screw O-ring	
Crankshaft end accessing screw O-ring	
Engine oil filler cap O-ring	
Starter clutch gear thrust surfaces and washer	
Starter clutch rollers and starter clutch gear boss	
Starter motor O-ring	
Starter clutch idle gear shaft and starter clutch idle gear inner surface	
Starter clutch idle gear thrust surfaces and washer	
Clutch push lever	
Primary driven gear inner surface	
Long clutch push rod	
Short clutch push rod and ball	
Clutch push rod ball	

**LUBRICATION POINTS AND LUBRICANT TYPES**

LUBRICATION POINT	LUBRICANT
Clutch lever shaft ball	
Clutch hub seating and thread	
Seat and nut of the cube of the clutch	
Main axle and pinion gears	
Drive axle and wheel gears	
Shift drum assembly	
Shift forks and shift fork guide bar	
Shift shaft	
Crankshaft position sensor/stator assembly lead grommet	Yamaha bond n° 1215 (Three Bond n° 1215®)
Crankcase mating surfaces	Yamaha bond n° 1215 (Three Bond n° 1215®)
Timing chain tensioner bolt threads	Yamaha bond n° 1215 (Three Bond n° 1215®)

**LUBRICATION SYSTEM CHART AND DIAGRAMS**

**ENGINE OIL LUBRICATION CHART**

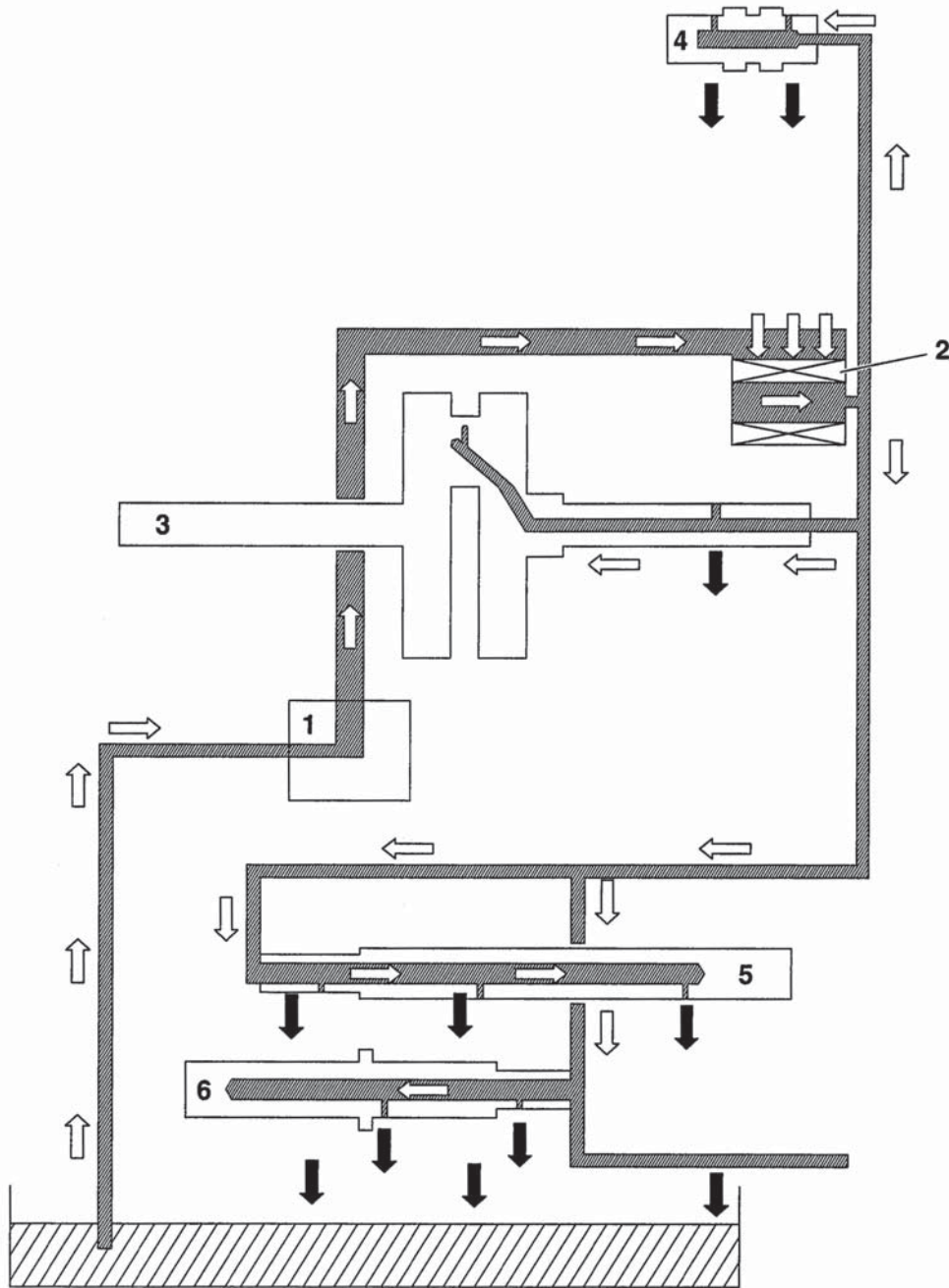

1. Oil pump
2. Oil filter element
3. Crankshaft
4. Camshaft
5. Main axle
6. Drive axle

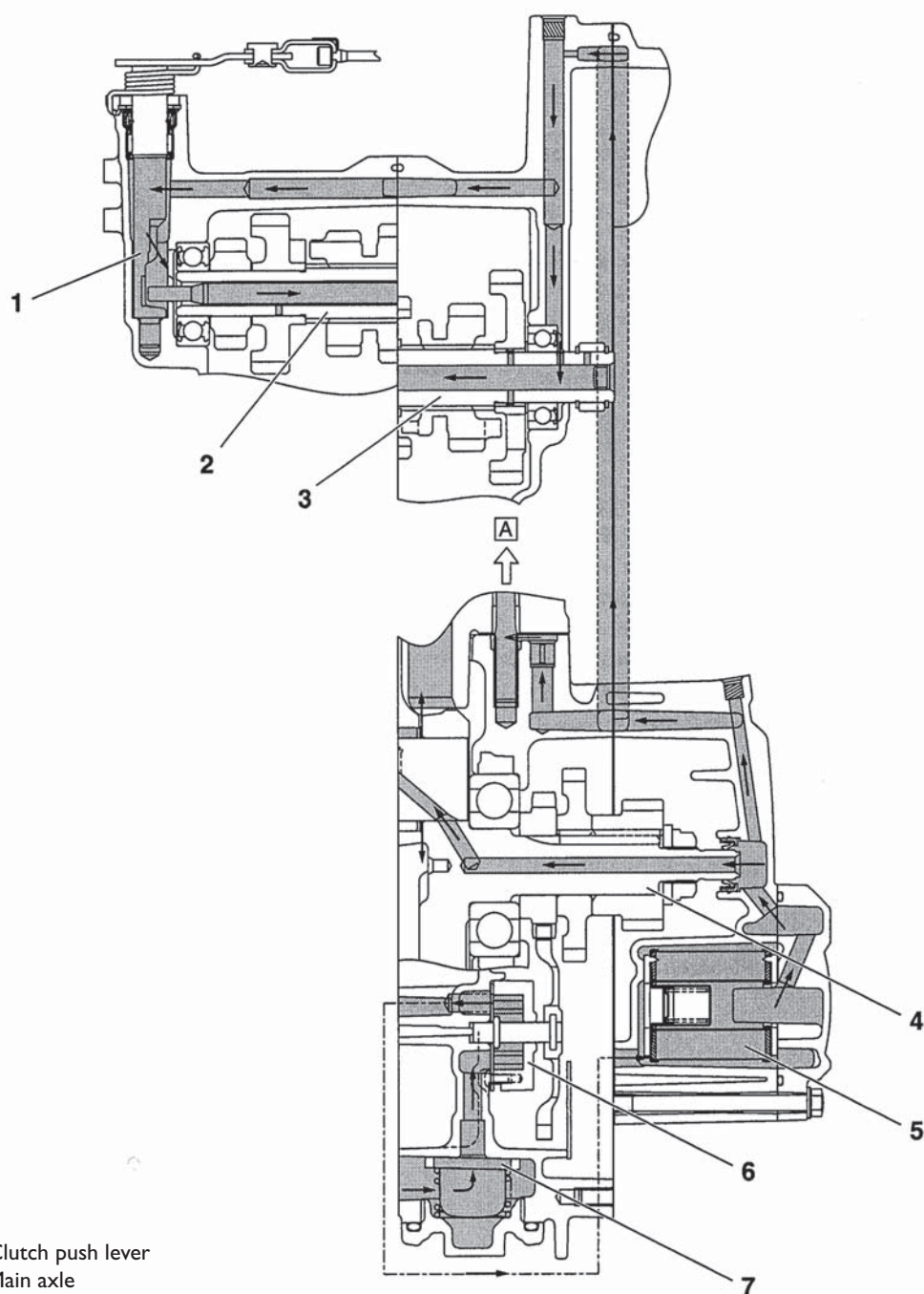
**LUBRICATION SYSTEM CHART AND DIAGRAMS****LUBRICATION DIAGRAMS**

- 1. Clutch push lever
- 2. Main axle
- 3. Drive axle
- 4. Cran kshaft
- 5. Oil fi lter
- 6. Oil pump assembly
- 7. Oil strainer
- A. To cylinder head

**LUBRICATION SYSTEM CHART AND DIAGRAMS**

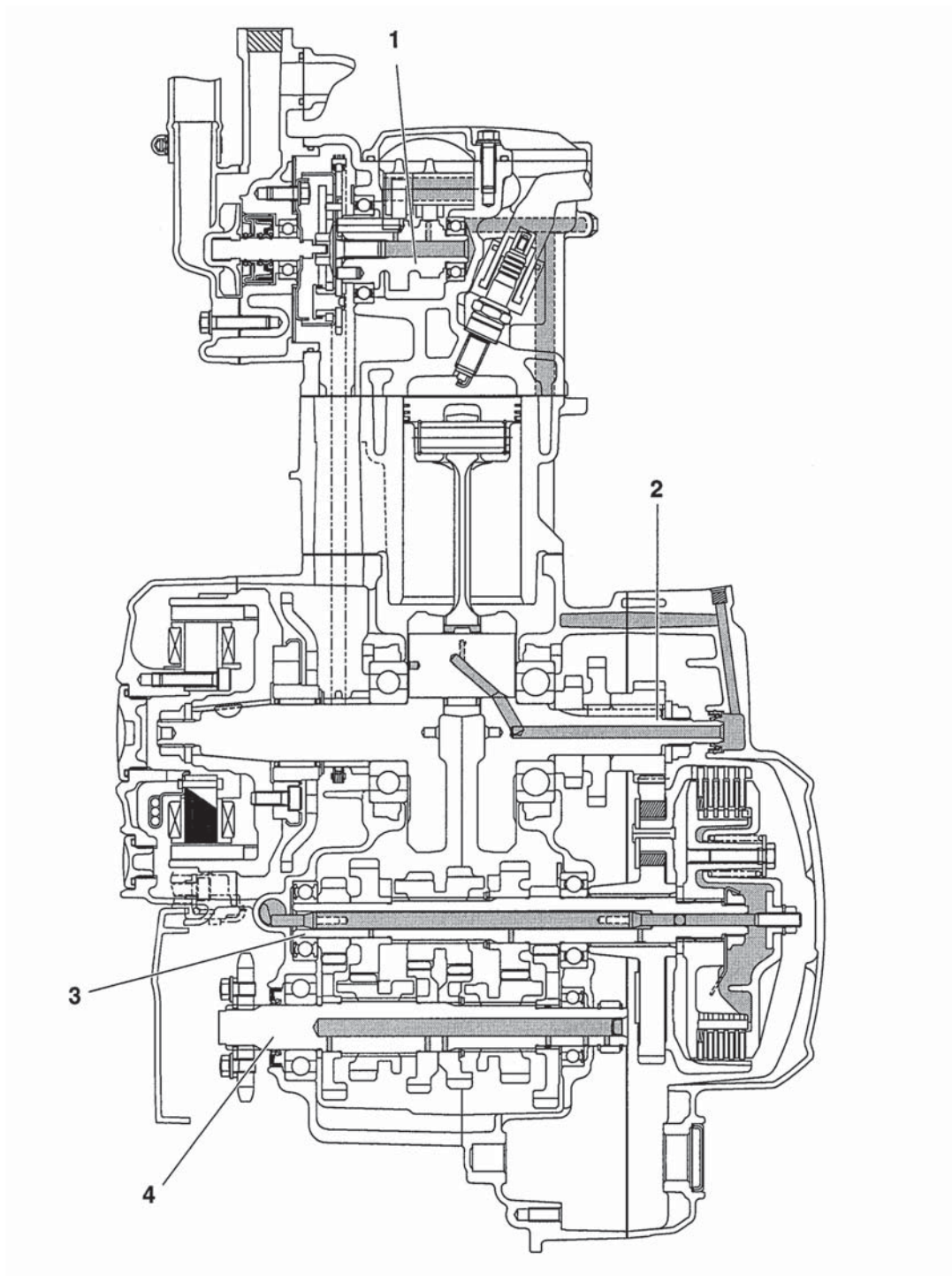

- 1. Camshaft
- 2. Crankshaft
- 3. Main axle
- 4. Drive axle



## PERIODIC MAINTENANCE

### IDENTIFICATION

This chapter includes all information necessary to perform recommended checks and adjustments. If followed, these preventive maintenance procedures will ensure more reliable vehicle operation, a longer service life and reduce the need for costly overhaul work. This information applies to vehicles already in service as well as to new vehicles that are being prepared for sale. All service technicians should be familiar with this entire chapter.

### PERIODIC MAINTENANCE AND LUBRICATION CHART

#### NOTE

THE ANNUAL CHECKS MUST BE PERFORMED EVERY YEAR, EXCEPT IF A KILOMETER-BASED MAINTENANCE, OR FOR THE UK, A MILEAGE-BASED MAINTENANCE, IS PERFORMED INSTEAD.

FROM 30000 KM (17500 MI), REPEAT THE MAINTENANCE INTERVALS STARTING FROM 6000 KM (3500 MI).

ITEMS MARKED WITH AN ASTERISK SHOULD BE PERFORMED BY A YAMAHA DEALER AS THEY REQUIRE SPECIAL TOOLS, DATA AND TECHNICAL SKILLS.

No.	ITEM	CHECK OR MAINTENANCE JOB	ODOMETER READING					ODOMETER READING	
			1000 km (600 mi)	6000 km (3500 mi)	12000 km (7000 mi)	18000 km (10500 mi)	24000 km (14000 mi)		
1	Fuel line	Check fuel hoses for cracks or damage.		√	√	√	√	√	
2	Spark plug	Check condition. Clean and regap.		√		√			
		Replace.			√				
3	Valves	Check valve clearance. Adjust.		√	√	√	√		
4	Clutch	Check operation. Adjust.	√	√	√	√	√		
5	Engine oil	Change.	√	2000 km (1200 mi) after the initial 1000 km (600 mi) and every 3000 km (1800 mi) thereafter					
		Check oil level and vehicle for oil leakage.		Every 3000 km (1800 mi)					√
6	Engine oil filter element	Replace.	√	√	√	√	√	√	

## ADJUSTING THE VALVE CLEARANCE

The following procedure applies to all of the valves.

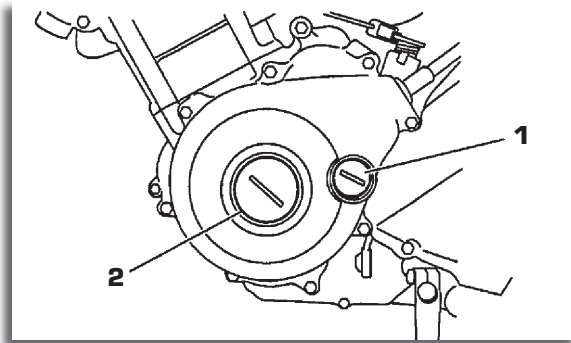

### NOTE

**VALVE CLEARANCE ADJUSTMENT SHOULD BE MADE ON A COLD ENGINE, AT ROOM TEMPERATURE.**

**WHEN THE VALVE CLEARANCE IS TO BE MEASURED OR ADJUSTED, THE PISTON MUST BE AT TOP DEAD CENTER (TDC) ON THE COMPRESSION STROKE.**

- Remove:
  - Cover of the cylinder head
  - Cylinder head cover gasket
 Refer to "CYLINDER HEAD"

### NOTE

**WHEN REMOVING THE CYLINDER HEAD COVER, LIFT IT OUT FROM BETWEEN THE FRAME TUBES.**

- Remove:
  - Timing mark accessing screw "1"
  - Crankshaft end accessing screw "2"
- Measure:
  - Valve clearance
 Out of specification -> Adjust.

	<b>Valve clearance (cold)</b>
	Intake
	0,10 - 0,14 mm (0,0039-0,0055")
	Exhaust
	0,20 - 0,24 mm (0,0079-0,0094")

### ADJUSTING THE VALVE CLEARANCE

- a) Turn the crankshaft counterclockwise.
- b) Align the TDC mark "a" on the generator rotor with the stationary pointer "b" on the generator cover.

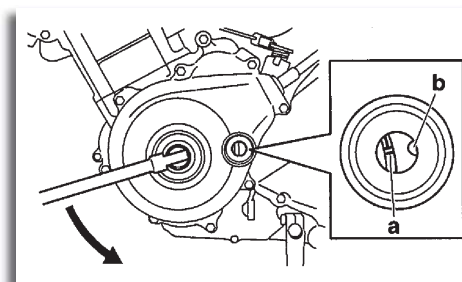

- c) Check that the cam lobes are positioned as shown in the illustration.
- d) Measure the valve clearance with a thickness gauge "1".  
Out of specification -> Adjust.

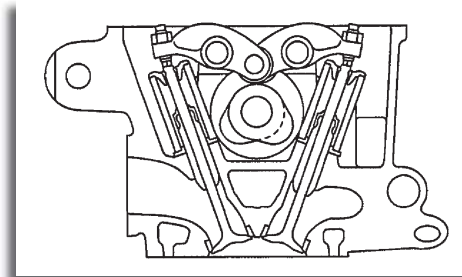

- Adjust:
  - Valve clearance

- a) Loosen the locknut "1".
- b) Insert a thickness gauge "2" between the end of the adjusting screw and the valve tip.
- c) Turn the adjusting screw "3" in direction "a" or "b" until the specified valve clearance is obtained.

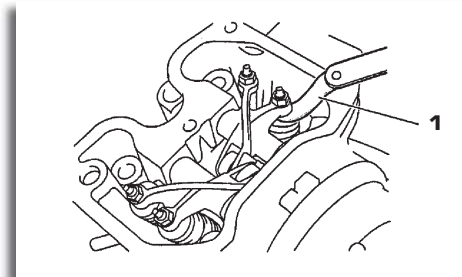

Direction "a"  
Valve clearance is increased.  
Direction "b"  
Valve clearance is decreased.

 Tappet adjusting tool  
90890-01311  
Six piece tappet set  
YM-A5970

- Hold the adjusting screw to prevent it from moving and tighten the locknut to specification.

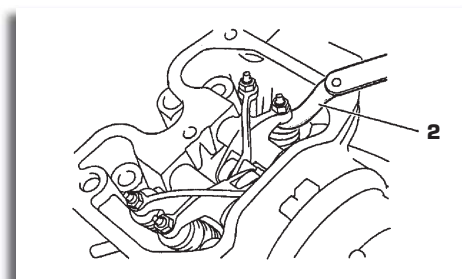

 Valve adjusting screw locknut  
7 Nm (0,7 m-kg, 5,1 ft-lb)

## ADJUSTING THE VALVE CLEARANCE

d) Measure the valve clearance again.

e) If the valve clearance is still out of specification, repeat all of the valve clearance adjustment steps until the specified clearance is obtained.

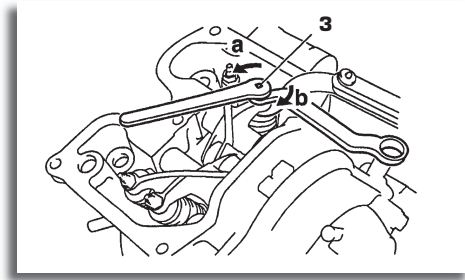

• Instal:

- Crankshaft end accessing screw (along with the O-ring New)
- Timing mark accessing screw (along with the O-ring New)

• Instal:

- Cylinder head cover gasket New
- Cylinder head cover
- Spark plug

• Instal:

- Ignition coil "4"



Ignition coil bolt  
7 Nm (0,7 m-kg, 5,1 ft-lb)

• Spark plug



Spark plug  
13 Nm (1,3 m-kg, 9,4 ft-lb)

• Disconnect:

- Spark plug cap

• Remove:

- Spark plug

### CAUTION

BEFORE REMOVING THE SPARK PLUG, BLOW AWAY ANY DIRT ACCUMULATED IN THE SPARK PLUG WELL WITH COMPRESSED AIR TO PREVENT IT FROM FALLING INTO THE CYLINDER.

• Check:

- Spark plug type Incorrect -> change



Manufacturer/model  
NGK/CR8E

## ADJUSTING THE VALVE CLEARANCE

- Check:
  - Electrode "1"
  - Damagelwear -> Replace the spark plug.
  - Insulator "2"
  - Abnormal color -> Replace the spark
- Clean:
  - Spark plug  
(with a spark plug cleaner or wire brush)
- Measure:
  - Spark plug gap "a"  
(with a wire thickness gauge)  
Out of specification -> Regap.

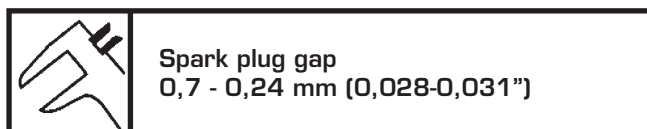

- Install:
  - Spark plug

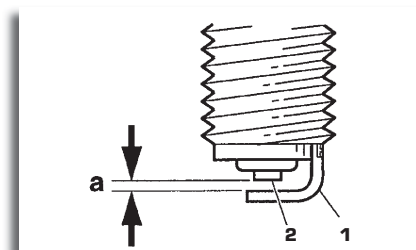
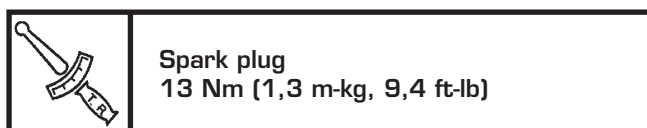

### NOTE

BEFORE INSTALLING THE SPARK PLUG, CLEAN THE SPARK PLUG AND GASKET SURFACE.

- Connect:
  - Spark plug cap

## CHECKING THE IGNITION TIMING

### NOTE

PRIOR TO CHECKING THE IGNITION TIMING, CHECK THE WIRING CONNECTIONS OF THE ENTIRE IGNITION SYSTEM. MAKE SURE ALL CONNECTIONS ARE TIGHT AND FREE OF CORROSION.

- Remove:
  - Timing mark accessing screw "1"
- Connect:
  - Timing light "1"
  - Digital tachometer

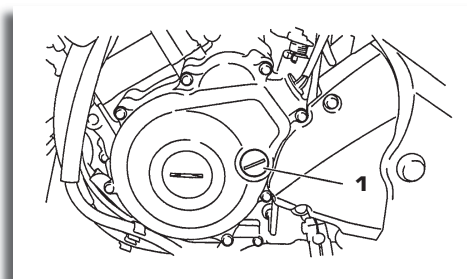
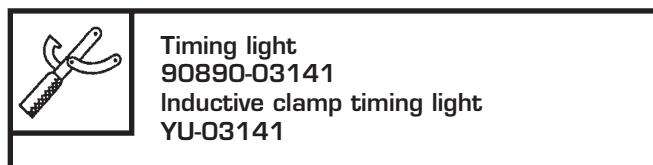

- Check:
  - Ignition timing

a) Start the engine, warm it up for several minutes, and then let it run at the specified engine idling speed.

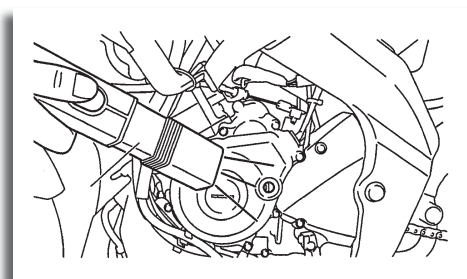
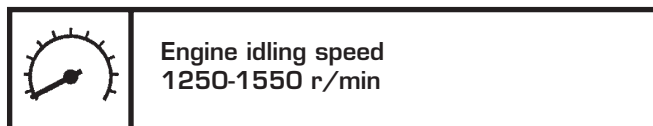

b) check that stationary pointer "a" in the generator cover is within the firing range "b" on the generator rotor. Incorrect firing range -> Check the ignition system.

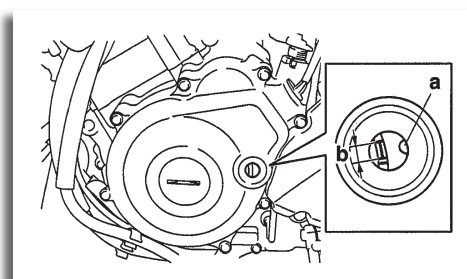

### NOTE

THE IGNITION TIMING IS NOT ADJUSTABLE.

- Remove:
  - Digital tachometer
  - Timing light
- Install:
  - Timing mark accessing screw  
(along with the O-ring **New**)

## MEASURING THE COMPRESSION PRESSURE

### NOTE

INSUFFICIENT COMPRESSION PRESSURE WILL RESULT IN A LOSS OF PERFORMANCE.

- Measure:
  - Valve clearance
  - Out of specification -> Adjust.
  - Refer to "ADJUSTING THE VALVE CLEARANCE."
- Start the engine, warm it up for several minutes, and then turn it off.
- Disconnect:
  - Coolant temperature sensor coupler "1"
  - Spark plug cap "2"
- Remove:
  - Spark plug

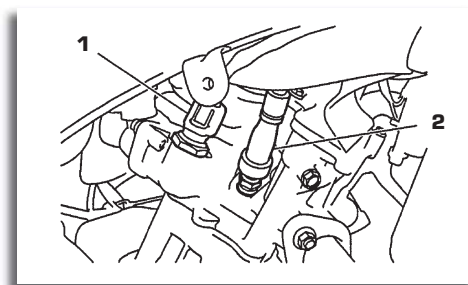

### CAUTION

BEFORE REMOVING THE SPARK PLUG, USE COMPRESSED AIR TO BLOW AWAY ANY DIRT ACCUMULATED IN THE SPARK PLUG WELL TO PREVENT IT FROM FALLING INTO THE CYLINDER.

- Install:
  - Extension "1"
  - Compression gauge "2"

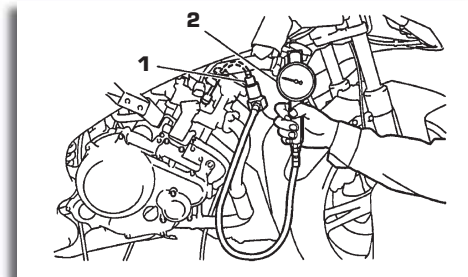
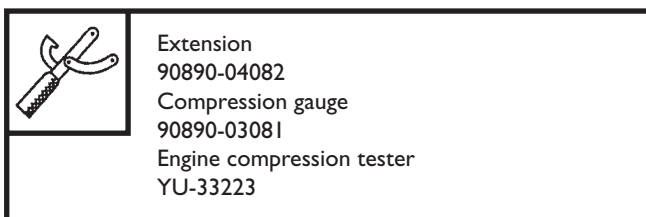

- Measure:
  - Compression pressure
  - Out of specification -> Refer to steps (c) and (d).

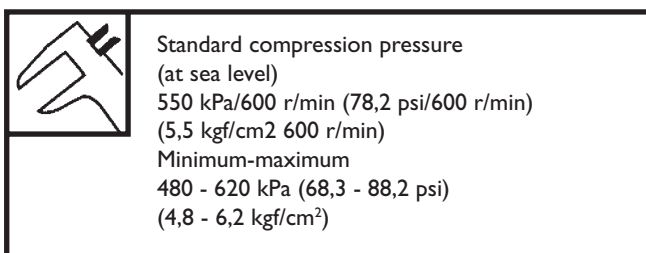

## MEASURING THE COMPRESSION PRESSURE

- a) Set the main switch to "ON".
- b) With the throttle wide open, crank the engine until the reading on the compression gauge stabilizes.
- c) If the compression pressure is above the maximum specification, check the cylinder head, valve surfaces and piston crown for carbon deposits.  
Carbon deposits -> Eliminate.
- d) If the compression pressure is below the minimum specification, pour a teaspoonful of engine oil into the spark plug bore and measure again.  
Refer to the following table.

Compression pressure (with oil applied into the cylinder)	
Reading	Diagnosis
Higher than without oil	Piston ring(s) wear or damage -> Repair.
Same as without oil	Piston, valves, cylinder head gasket or piston possibly defective -> Repair.

- Remove:
  - Extension
  - Compression gauge
- Install:
  - Spark plug



Spark plug  
13 Nm (1,3 m·kg, 9,4 ft·lb)

- Connect:
  - Spark plug cap
  - Coolant temperature sensor coupler



## CHECKING THE ENGINE OIL LEVEL

- Stand the vehicle on a level surface.

### NOTE

PLACE THE VEHICLE ON A SUITABLE STAND.

MAKE SURE THE VEHICLE IS UPRIGHT.

- Start the engine, warm it up for several minutes, and then turn it off.
- Check:
  - Engine oil level

The engine oil level should be between the minimum level mark "a" and maximum level mark "b".  
Below the minimum level mark -> Add the recommended engine oil to the proper level.

### NOTE

BEFORE CHECKING THE ENGINE OIL LEVEL, WAIT A FEW MINUTES UNTIL THE OIL HAS SETTLED.

DO NOT SCREW THE ENGINE OIL FILLER CAP (DIPSTICK) "1" IN WHEN CHECKING THE OIL LEVEL.

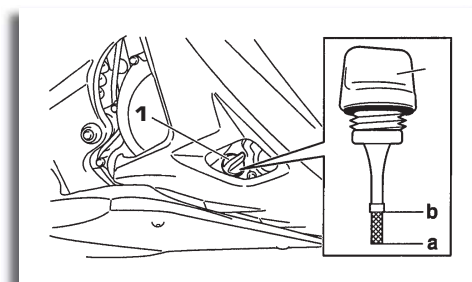

### Type

SAE 10W-30, SAE 10W-40, SAE 15W-40,  
SAE 20W-40 o SAE 20W-50

Recommended engine oil grade API service SG  
type or higher, JASO standard MA

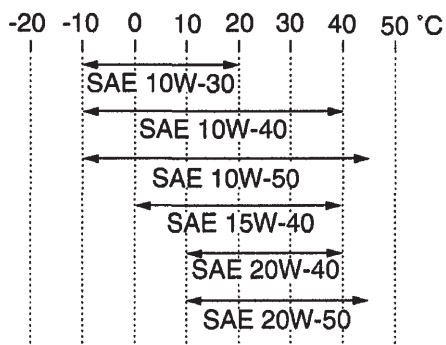

## Engine

### CAUTION

ENGINE OIL ALSO LUBRICATES THE CLUTCH AND THE WRONG OIL TYPES OR ADDITIVES COULD CAUSE CLUTCH SLIPPAGE. THEREFORE, DO NOT ADD ANY CHEMICAL ADDITIVES OR USE ENGINE OILS WITH A GRADE OF "CD" "c" OR HIGHER AND DO NOT USE OILS LABELED "ENERGY CONSERVING II" "d".

DO NOT ALLOW FOREIGN MATERIALS TO ENTER THE CRANKCASE.

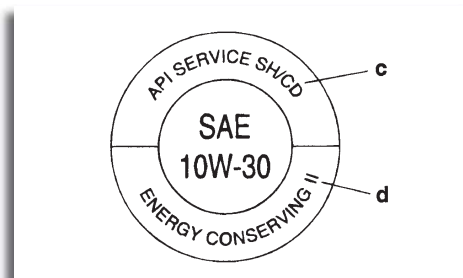

- Start the engine, warm it up for several minutes, and then turn it off.
- Check the engine oil level again.

### NOTE

BEFORE CHECKING THE ENGINE OIL LEVEL, WAIT A FEW MINUTES UNTIL THE OIL HAS SETTLED.

## CHANGING THE ENGINE OIL

- Start the engine, warm it up for several minutes, and then turn it off.
- Place a container under the engine oil drain bolt.
- Install:
  - Engine oil drain attachment "1" (Located under the rider seat with the owner's tool kit)
- Remove:
  - Engine oil filler cap (dipstick) "1"
  - Engine oil drain plug "2"
  - O-ring "3"
  - Spring "4"
  - Engine oil strainer "5"
- Drain:
  - Engine oil (completely from the crankcase)
- If the oil filter element is also to be replaced, perform the following procedure.

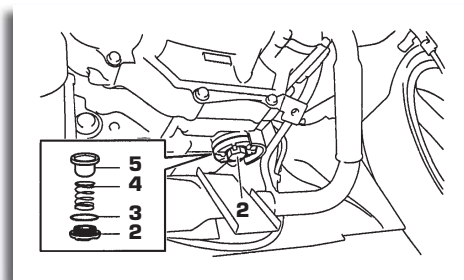
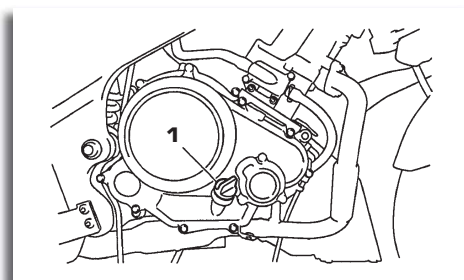
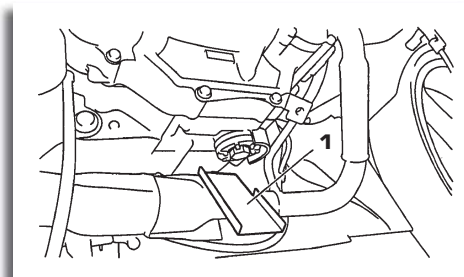

a) Remove the oil fi lter element cover "1" and oil fi lter element "2".

b) Install the new O-ring "3" - **New**

c) Install the new oil fi lter element and the oil fi lter element cover.



Oil fi lter element cover bolt  
10 Nm (1,0 m-kg, 7,2 ft-lb)

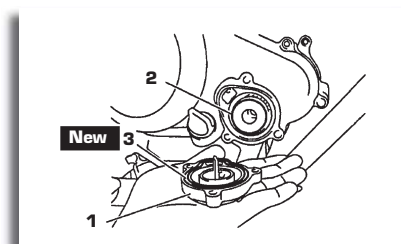

• Check:

- Engine oil strainer  
Dirt -> Clean.

• Install:

- Engine oil strainer
- Spring
- O-ring - **New**
- Engine oil drain plug



Engine oil drain plug  
32 Nm (3,2 m-kg, 23 ft-lb)

• Fill:

- Crankcase  
(with the specifi ed amount of the recommended engine oil).



Engine oil quantity  
Total amount  
1,15 L (1,22 US qt) (1,01 Imp. qt)  
Without oil fi lter element replacement  
0,95 L (1,00 US qt) (0,84 Imp. qt)  
With oil fi lter element replacement  
1,00 l (1,06 US qt) (0,88 Imp. qt)

• Install:

- Engine oil fi ller cap
- Start the engine, warm it up for several minutes, and then turn it off.

• Check:

- Engine  
(for engine oil leaks)

• Check:

- Engine oil level  
Refer to "CHECKING THE ENGINE OIL LEVEL"

• Check:

- Engine oil pressure

## Engine

- a) Slightly loosen the oil check bolt "1".
- b) Start the engine and keep it idling until engine oil starts to seep from the oil check bolt. If no engine oil comes out after one minute, turn the engine off so that it will not seize.
- c) Check the engine oil passages, the oil filter element and the oil pump for damage or leakage. Refer to "OIL PUMP".
- d) Start the engine after solving the problem(s) and check the engine oil pressure again.
- e) Tighten the oil check bolt to specification.

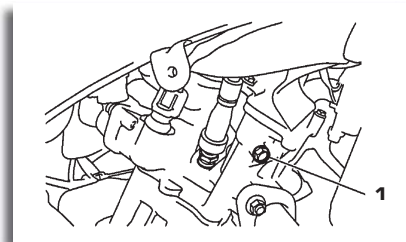

Oil check bolt  
7 Nm (0,7 m·kg, 5,1 ft·lb)

## ADJUSTING THE CLUTCH CABLE FREE PLAY

### Engine end

- a) Loosen the locknut "1".
- b) Turn the adjusting nut "2" in direction "a" or "b" until the specified clutch cable free play is obtained.

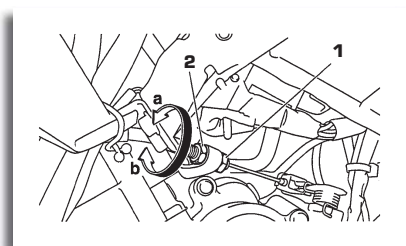

Direction "a"  
Clutch cable free play is increased.  
Direction "b"  
Clutch cable free play is decreased.

- c) Tighten the locknut.

**THERMOSTAT**

Removing the thermostat

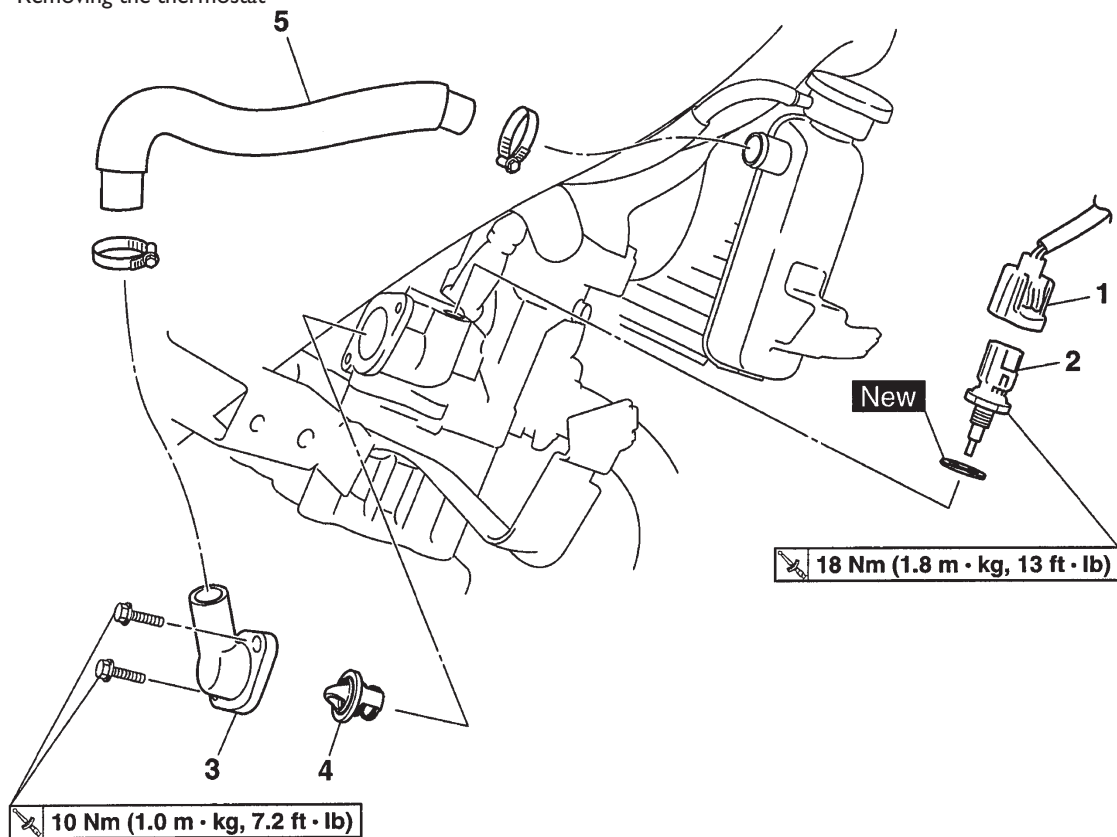

Order	Job/Parts to remove	Q'ty	Remarks
1	Coolant temperature sensor coupler	1	Disconnect
2	Coolant temperature sensor	1	
3	Thermostat cover	1	
4	Thermostat	1	
5	Radiator inlet hose	1	
			For installation, reverse the removal procedure.



## CHECKING THE THERMOSTAT

- Check:
  - Thermostat
 Does not open at 80.5-83.5 °C (176.9-182.3 °F) -> Replace.
- a) Suspend the thermostat "1" in a container "2" filled with water.
- b) Slowly heat the water "3"
- c) Place a thermometer "4" in the water.
- d) While stirring the water, observe the thermostat and thermometer's indicated temperature.

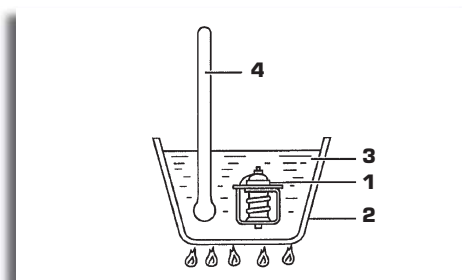
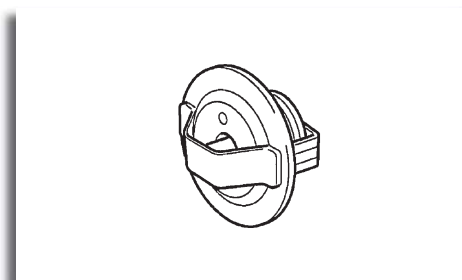

A. Fully closed  
B. Fully open

NOTE  
IF THE ACCURACY OF THE THERMOSTAT IS IN DOUBT, REPLACE IT. A FAULTY THERMOSTAT COULD CAUSE SERIOUS OVERHEATING OR OVERCOOLING.

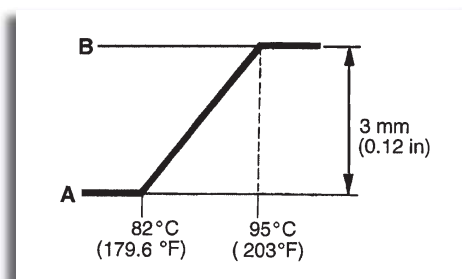

- Check:
  - Thermostat cover
 Cracks/damage -> Replace.
- Check:
  - Radiator inlet hose
 Cracks/damage -> Replace.

## INSTALLING THE THERMOSTAT

- Install:
  - Thermostat

NOTE  
INSTALL THE THERMOSTAT WITH ITS BREATHER HOLE  
“a” FACING UP.

- Install:
  - Copper washer - **New**
  - Coolant temperature sensor

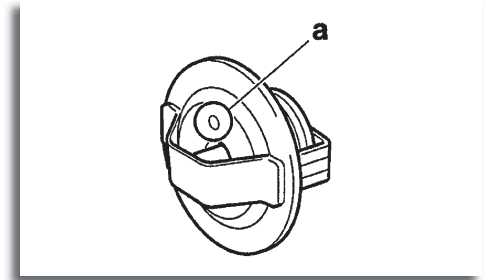

Coolant temperature sensor  
18 Nm (1,8 m-kg, 13 ft-lb)

CAUTION  
USE EXTREME CARE WHEN HANDLING THE COOLANT TEM-  
PERATURE SENSOR. REPLACE ANY PART THAT WAS DROPPED  
OR SUBJECTED TO A STRONG IMPACT.

**WATER PUMP**

Removing the water pump

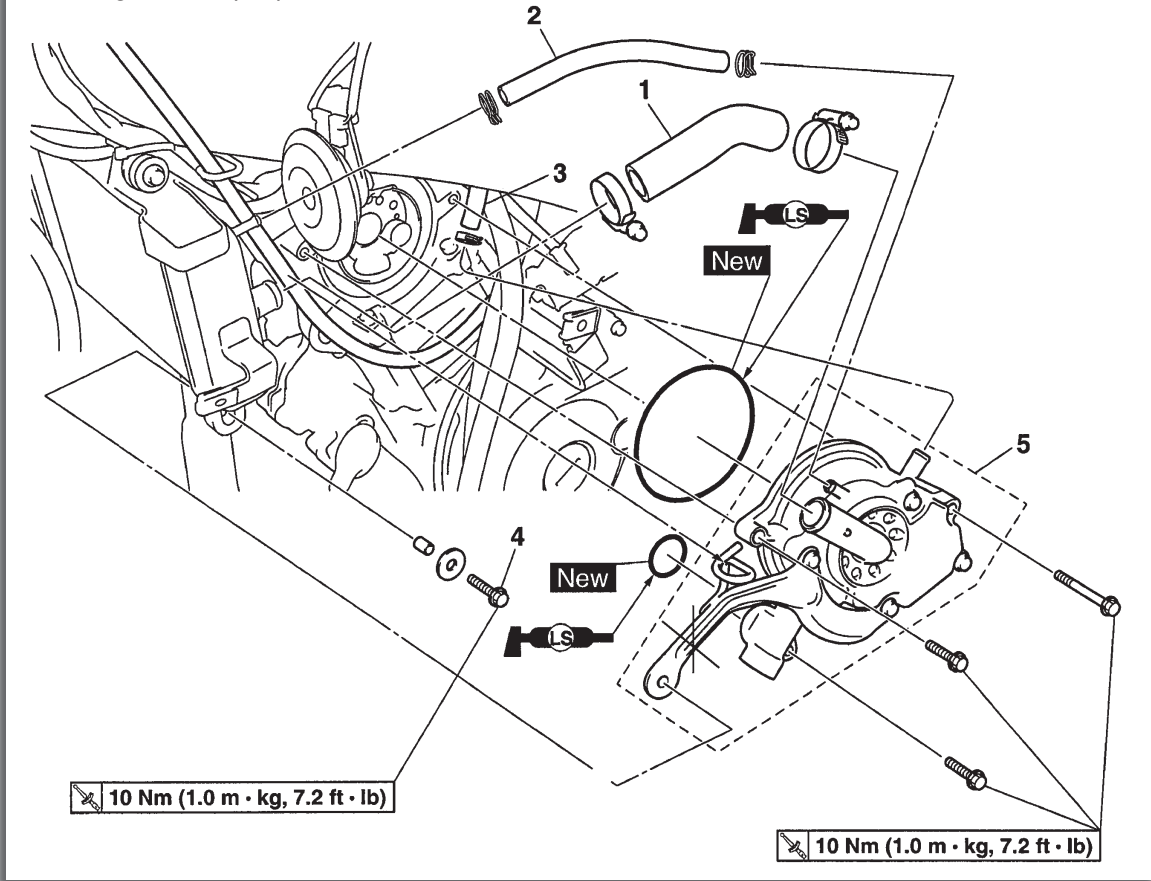

Order	Job/Parts to remove	Q'ty	Remarks
			It is not necessary to remove the water pump unless the coolant level is extremely low or the coolant contains engine oil.
1	Radiator outlet hose	1	Disconnect
2	Water pump breather hose	1	
3	Cylinder head breather hose	1	
4	Radiator bolt	1	
5	Water pump assembly	1	
			For installation, reverse the removal procedure.



**WATER PUMP**

Disassembling the water pump

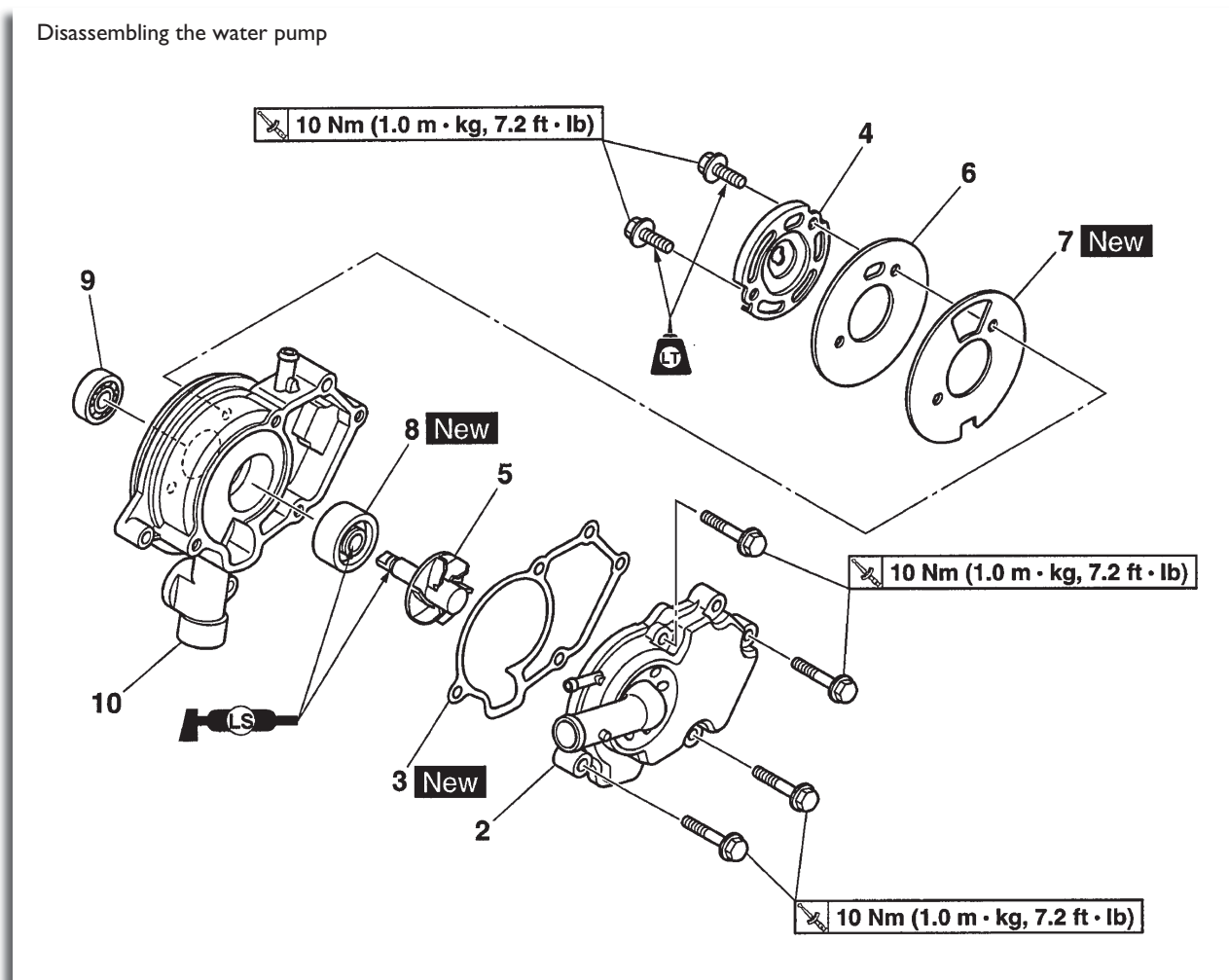

Order	Job/Parts to remove	Q'ty	Remarks
1	Water pump housing cover	1	
2	Water pump housing cover gasket	1	
3	Impeller shaft retainer	1	
4	Impeller shaft	1	
5	Water pump housing plate	1	
6	Water pump housing gasket	1	
7	Water pump seal	1	
8	Bearing	1	
9	Water pump housing	1	
			For assembly, reverse the disassembly procedure.

## DISASSEMBLING THE WATER PUMP

- Remove:
  - Water pump seal "1"

NOTE  
REMOVE THE WATER PUMP SEAL FROM THE INSIDE OF THE WATER PUMP HOUSING "2".

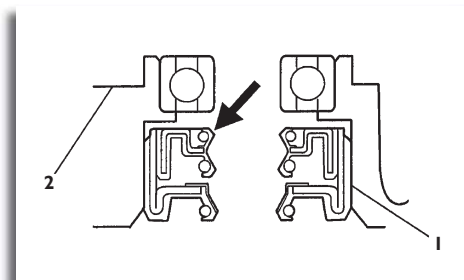

- Remove:
  - Bearing "1"

NOTE  
REMOVE THE BEARING FROM THE OUTSIDE OF THE WATER PUMP HOUSING "2".

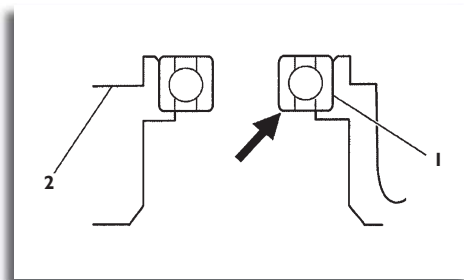

## CHECKING THE WATER PUMP

- Check:
  - Water pump housing cover
  - Water pump housing  
Cracks/damage -> Replace.
  - Impeller shaft  
Cracks/damage/wear -> Replace.
  - Bearing  
Rough movement -> Replace.
  - Radiator outlet hose  
Cracks/damage -> Replace.

## ASSEMBLING THE WATER PUMP

- Install:
  - Water pump seal "1" - **New**  
(into the water pump housing "2")

CAUTION  
NEVER LUBRICATE THE WATER PUMP SEAL SURFACE WITH OIL OR GREASE.

NOTE  
INSTALL THE WATER PUMP SEAL WITH THE SPECIAL TOOLS.

INSTALL THE WATER PUMP SEAL WITH THE SPECIAL TOOLS TO THE SPECIFIED DEPTH AS SHOWN IN THE ILLUSTRATION.

	Mechanical seal installer 90890-041 45
	Middle driven shaft bearing driver 90890-04058
	Bearing driver 40 mm YM-04058

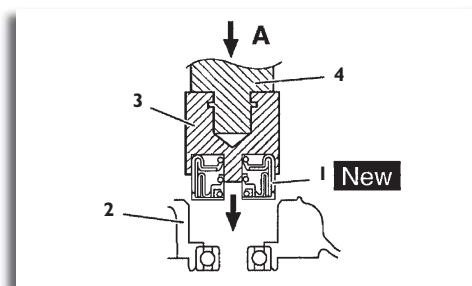

A. Push down

3. Mechanical seal installer

4. Middle driven shaft bearing driver

a) 0 - 0,5 mm (0 - 0,02 in)

- Lubricate:
  - Water pump seal lip

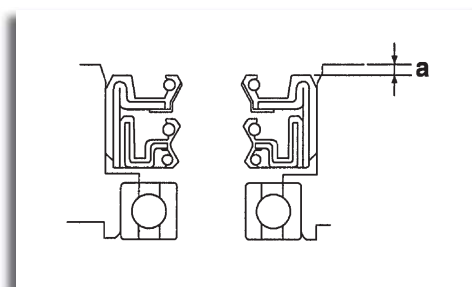

	Recommended lubricant Lithium-soap-based grease
--	--

- Install:
  - Water pump housing gasket "1" – **New**
  - Water pump housing plate "2"
  - Impeller shaft
  - Impeller shaft retainer "3"

	Impeller shaft retainer bolt 10 Nm (1,0 m-kg, 7,2 ft-lb) LOCTITE®
---	---

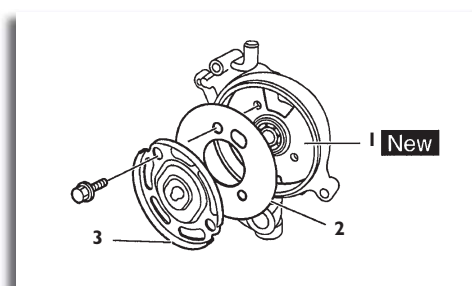

**NOTE**  
BEFORE INSTALLING THE IMPELLER SHAFT RETAINER, LUBRICATE THE SLIT ON THE IMPELLER SHAFT END WITH A THIN COAT OF LITHIUM-SOAP-BASED GREASE.

INSTALL THE WATER PUMP HOUSING GASKET, WATER PUMP HOUSING PLATE, AND IMPELLER SHAFT RETAINER AS SHOWN IN THE ILLUSTRATION.

AFTER INSTALLATION, CHECK THAT THE IMPELLER SHAFT ROTATES SMOOTHLY.

## INSTALLING THE WATER PUMP

- Install:
  - Water pump assembly "1 "
  - O-rings "2" - **New**

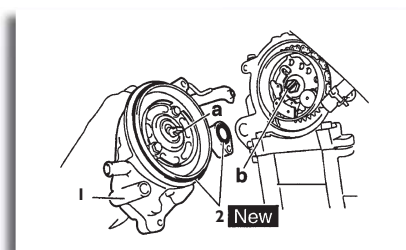

NOTE  
ALIGN THE PROJECTION "a" ON THE IMPELLER SHAFT WITH  
THE SLIT "b" ON THE CAMSHAFT SPROCKET BOLT.

LUBRICATE THE O-RINGS WITH A THIN COAT OF LITHIUM-  
SOAP-BASED GREASE.

**CYLINDER HEAD**

Removing the cylinder head

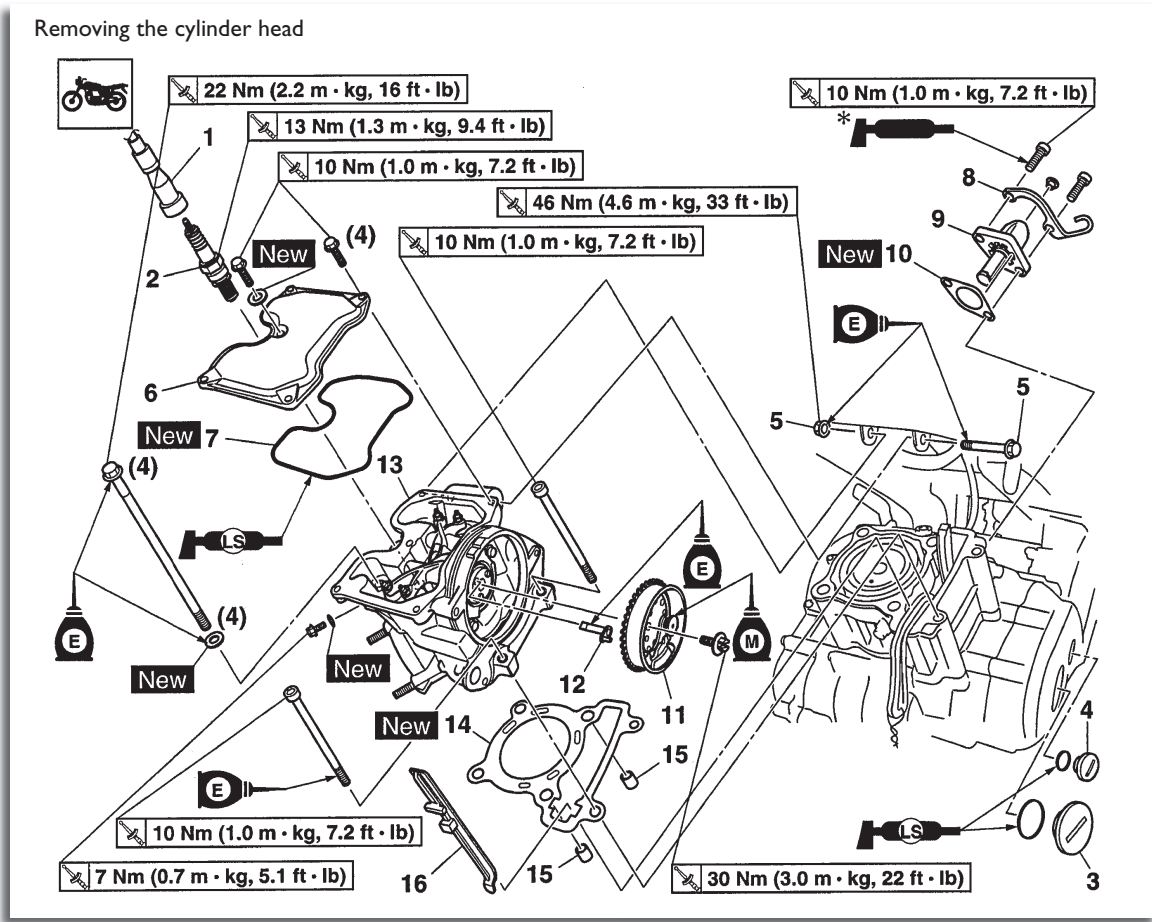

Order	Job/Parts to remove	Q'ty	Remarks
1	Spark plug cap	1	Disconnect
2	Spark plug	1	
3	Crankshaft end accessing screw	1	
4	Timing mark accessing screw	1	
5	Engine mounting bolt/nut (front side)	1/1	
6	Cylinder head cover	1	
7	Cylinder head cover gasket	1	
8	Clutch cable holder	1	
9	Timing chain tensioner	1	
10	Timing chain tensioner gasket	1	
11	Camshaft sprocket	1	
12	Decompression cam	1	
13	Cylinder head	1	
14	Cylinder head gasket	1	

CYLINDER HEAD

Removing the cylinder head

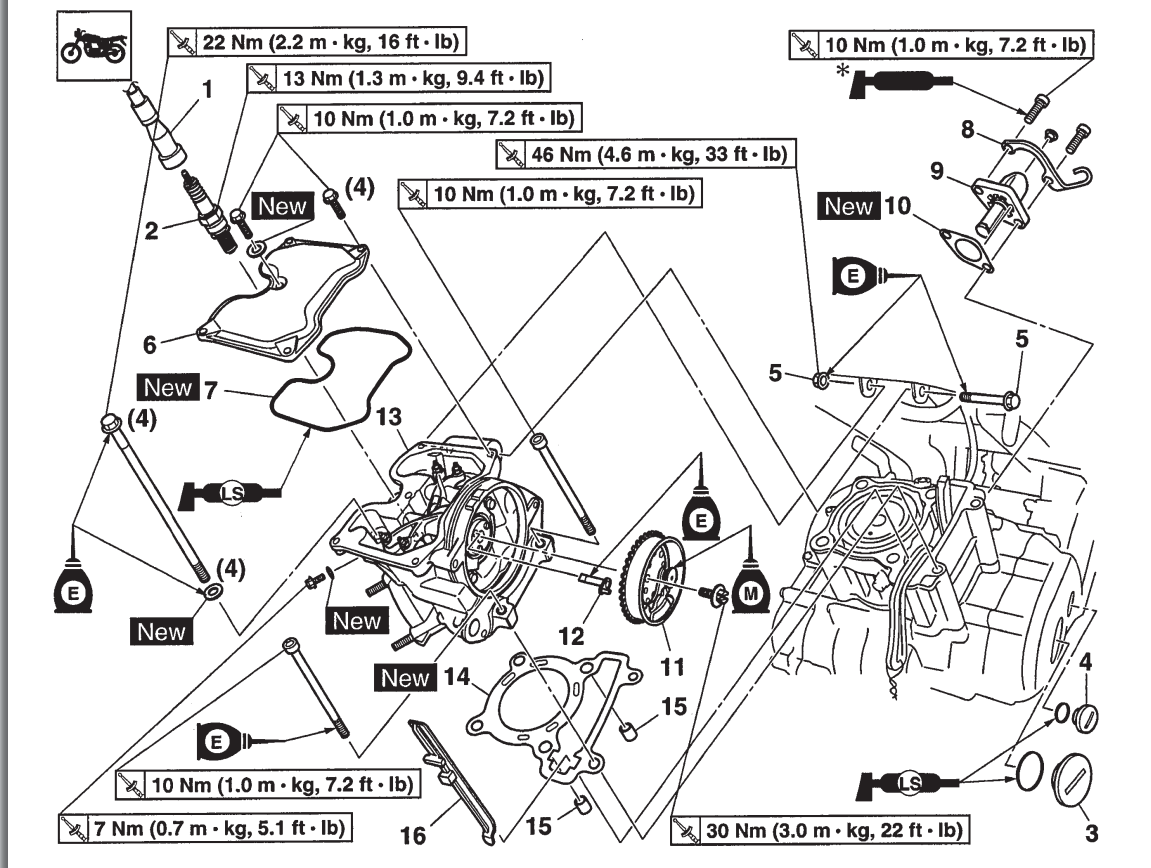

Order	Job/Parts to remove	Q'ty	Remarks
15	Dowel pin	2	
16	Timing chain guide (exhaust side)	1	
			For installation, reverse the removal procedure.

\*Yamaha bond No. 1215 (Three Bond No. 1215®)

## REMOVING THE CYLINDER HEAD

- Align:
    - "I" mark "a" on the generator rotor  
(with the stationary pointer "b" on the generator cover)
- a) Turn the crankshaft counterclockwise.
- b) When the piston is at TDC on the compression stroke, align the "I" mark "c" on the camshaft sprocket with the mark "d" on the cylinder head.

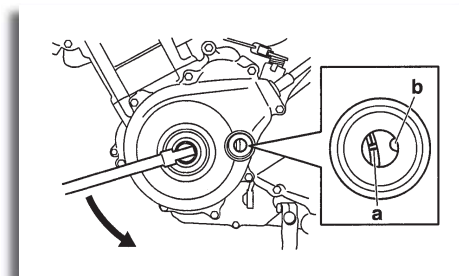

- Loosen:
  - Camshaft sprocket bolt "I"

**NOTE**  
WHILE HOLDING THE GENERATOR ROTOR NUT WITH A WRENCH "2", LOOSEN THE CAMSHAFT SPROCKET BOLT.

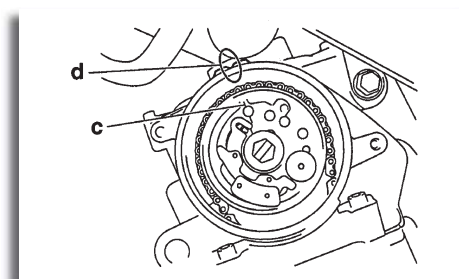

- Remove:
  - Camshaft sprocket

**NOTE**  
TO PREVENT THE TIMING CHAIN FROM FALLING INTO THE CRANKCASE, FASTEN IT WITH A WIRE "1".

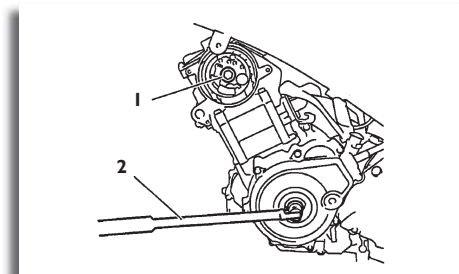

- Remove:
  - Cylinder head

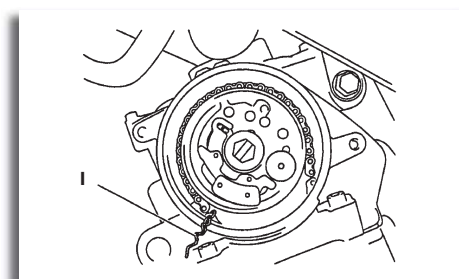

## Engine

### NOTE

LOOSEN THE BOLTS IN THE PROPER SEQUENCE AS SHOWN.

LOOSEN EACH BOLT 1/2 OF A TURN AT A TIME. AFTER ALL OF THE BOLTS ARE FULLY LOOSENED, REMOVE BOLTS 1, 2, 4, AND 6, AND THEN REMOVE THE CYLINDER HEAD WITH BOLTS 3 AND 5 INSTALLED IN THE BOLT HOLES.

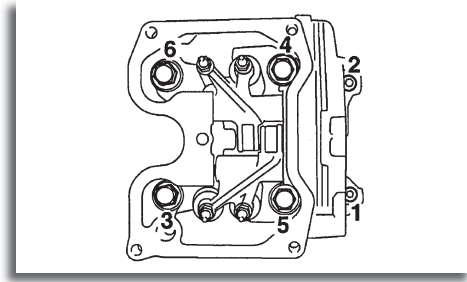

## CHECKING THE CYLINDER HEAD

- Eliminate:
  - Combustion chamber carbon deposits (with a rounded scraper)

### NOTE

DO NOT USE A SHARP INSTRUMENT TO AVOID DAMAGING OR SCRATCHING:

SPARK PLUG BORE THREADS

VALVE SEATS

- Check:
  - Cylinder head  
Damagelscratches -> Replace.
  - Cylinder head water jacket  
Mineral deposits/rust -> Eliminate.
- Measure:
  - Cylinder head warpage  
Out of specification -> Resurface the cylinder head.

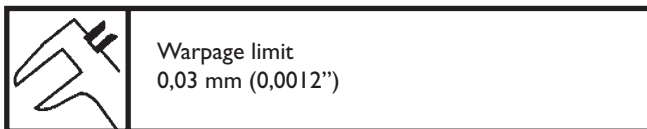
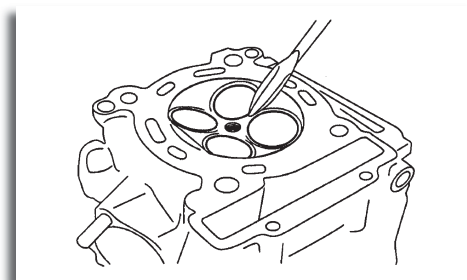

a) Place a straightedge "1" and a thickness gauge "2" across the cylinder head.

b) Measure the warpage.

c) If the limit is exceeded, resurface the cylinder head as follows.

d) Place a 400-600 grit wet sandpaper on the surface plate and resurface the cylinder head using a figure-eight sanding pattern.

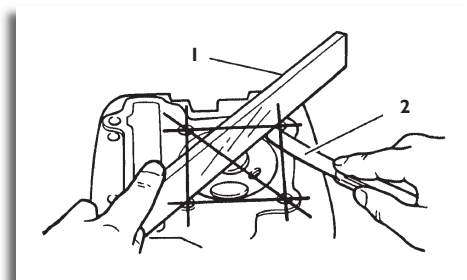

### NOTE

TO ENSURE AN EVEN SURFACE, ROTATE THE CYLINDER HEAD SEVERAL TIMES.



## CHECKING THE CAMSHAFT SPROCKET AND TIMING CHAIN GUIDE

- Check:
  - Camshaft sprocket
    - More than 1/4 tooth wear "a" -> Replace the camshaft sprocket, timing chain and crankshaft as a set.
    - a) 1/4 tooth
    - b. Correct
    - 1. Timing chain roller
    - 2. Camshaft sprocket
- Check:
  - Timing chain guide (exhaust side)
    - Damagelwear -> Replace.

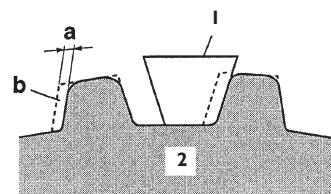

## CHECKING THE TIMING CHAIN TENSIONER

- Check:
  - Timing chain tensioner
    - Cracks/damagelrough movement -> Replace.

a) Lightly press the timing chain tensioner rod into the timing chain tensioner housing by hand.

NOTE  
WHILE PRESSING THE TIMING CHAIN TENSIONER ROD, WIND IT CLOCKWISE WITH A THIN SCREWDRIVER "I" UNTIL IT STOPS.

b) Remove the screwdriver and slowly release the timing chain tensioner rod.

c) Make sure that the timing chain tensioner rod comes out of the timing chain tensioner housing smoothly. If there is rough movement, replace the timing chain tensioner.

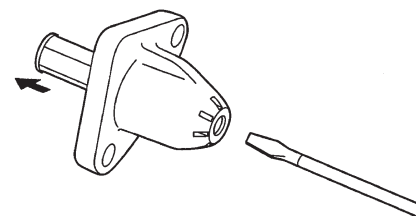
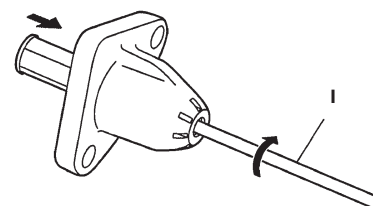

## CHECKING THE DECOMPRESSION SYSTEM

- Check:
  - Decompression system
- a) Check the decompression system with the camshaft sprocket and the decompression cam installed to the camshaft.
- b) Check that the decompression lever "1" moves smoothly.
- c) Without operating the decompression lever, check that the decompression cam "2" projects from the camshaft (exhaust cam) as shown in the illustration "A".
- d) Move the decompression lever "1" in the direction of the arrow shown and check that the decompression cam does not project from the camshaft (exhaust cam) as shown in the illustration "B".

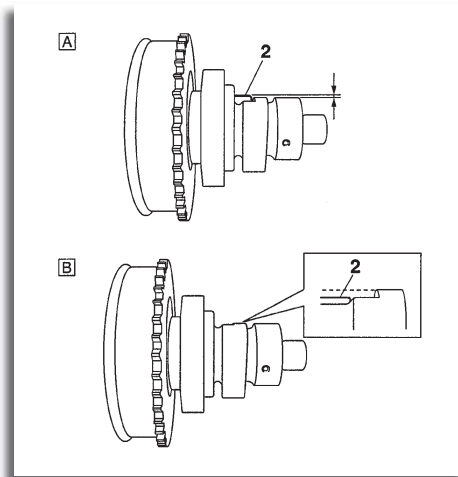
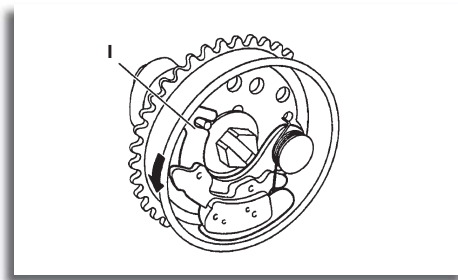

## INSTALLING THE CYLINDER HEAD

- Install:
  - Cylinder head

NOTE  
PASS THE TIMING CHAIN THROUGH THE TIMING CHAIN CAVITY.

- Tighten:
  - Cylinder head bolts "1"

	Cylinder head bolt 22 Nm (2,2 m-kg, 16 ft-lb)
--	--

- Cylinder head bolts "2"

	Cylinder head bolt 10 Nm (1,0 m-kg, 7,2 ft-lb)
--	---

NOTE  
LUBRICATE THE CYLINDER HEAD BOLTS AND WASHERS  
WITH ENGINE OIL.

TIGHTEN THE CYLINDER HEAD BOLTS IN THE PROPER  
TIGHTENING SEQUENCE AS SHOWN AND TORQUE THEM  
IN TWO STAGES.

- Install:
  - Camshaft sprocket

a) Turn the crankshaft counterclockwise.

b) Align the "I" mark "a" on the generator rotor with the stationary  
pointer "b" on the generator cover.

c) Align the "I" mark "c" on the camshaft sprocket with the station-  
ary pointer "d" on the cylinder head.

d) Install the timing chain onto the camshaft sprocket, and then  
install the camshaft sprocket onto the camshaft.

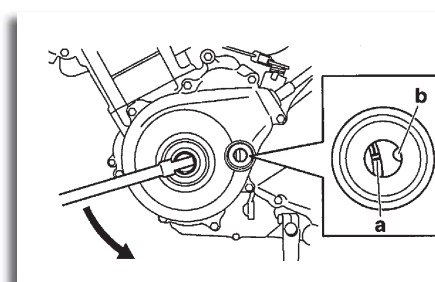
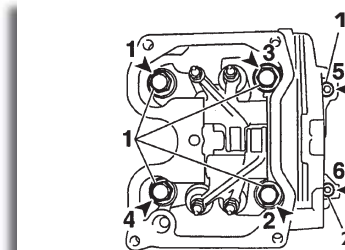

NOTE  
WHEN INSTALLING THE CAMSHAFT SPROCKET, BE SURE TO  
KEEP THE TIMING CHAIN AS TIGHT AS POSSIBLE ON THE EX-  
HAUST SIDE.

CAUTION  
DO NOT TURN THE CRANKSHAFT WHEN INSTALLING THE  
CAMSHAFT(S) TO AVOID DAMAGE OR IMPROPER VALVE TI-  
MING.

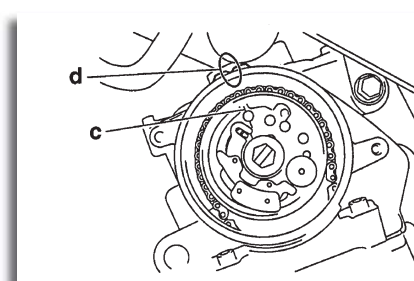

e) While holding the camshaft, temporarily tighten the camshaft  
sprocket bolt.

f) Remove the wire from the timing chain.

- Install:
  - Timing chain tensioner gasket - **New**
  - Timing chain tensioner

a) Apply sealant to the timing chain tensioner bolt threads.



Yamaha bond n° 1215  
90890-85505  
(Three Bond n° 1215®)

## Engine

b) While lightly pressing the timing chain tensioner rod by hand, turn the tensioner rod fully clockwise with a thin screwdriver "1".

c) With the timing chain tensioner rod turned all the way into the timing chain tensioner housing (with the thin screwdriver still installed), install the gasket and the timing chain tensioner "2" onto the cylinder block.

d) Tighten the timing chain tensioner bolts "3" to the specified torque.

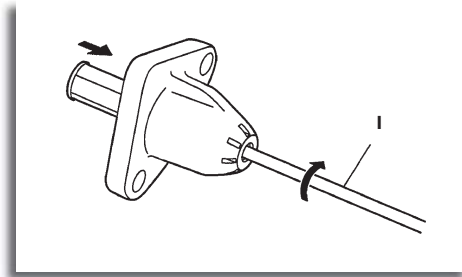

Timing chain tensioner bolt  
10 Nm (1,0 m-kg, 7,2 ft-lb)

e) Remove the screwdriver, make sure the timing chain tensioner rod releases.

• Turn:

- Crankshaft  
(several turns counterclockwise)

• Check:

- "I" mark "a"  
Align the "I" mark on the generator rotor with the stationary pointer "b" on the generator cover.
- "I" mark "c"  
Align the "I" mark on the camshaft sprocket with the stationary pointer "d" on the cylinder head.  
Out of alignment -> Correct.  
Refer to the installation steps above.

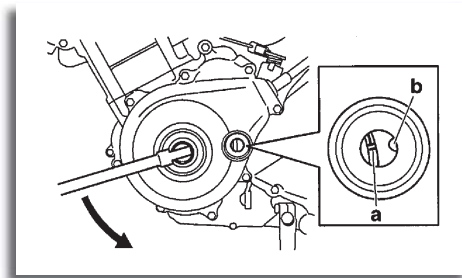

• Tighten:

- Camshaft sprocket bolt



Camshaft sprocket bolt  
30 Nm (3,0 m-kg, 22 ft-lb)

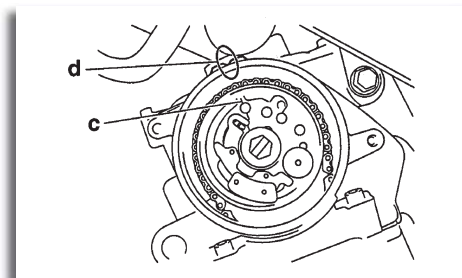

**CAUTION**

BE SURE TO TIGHTEN THE CAMSHAFT SPROCKET BOLT TO THE SPECIFIED TORQUE TO AVOID THE POSSIBILITY OF THE BOLT COMING LOOSE AND DAMAGING THE ENGINE.

• Measure:

- Valve clearance  
Out of specification -> Adjust.  
Refer to "ADJUSTING THE VALVE CLEARANCE"

**CAMSHAF**

Removing the rocker arms and camshaft

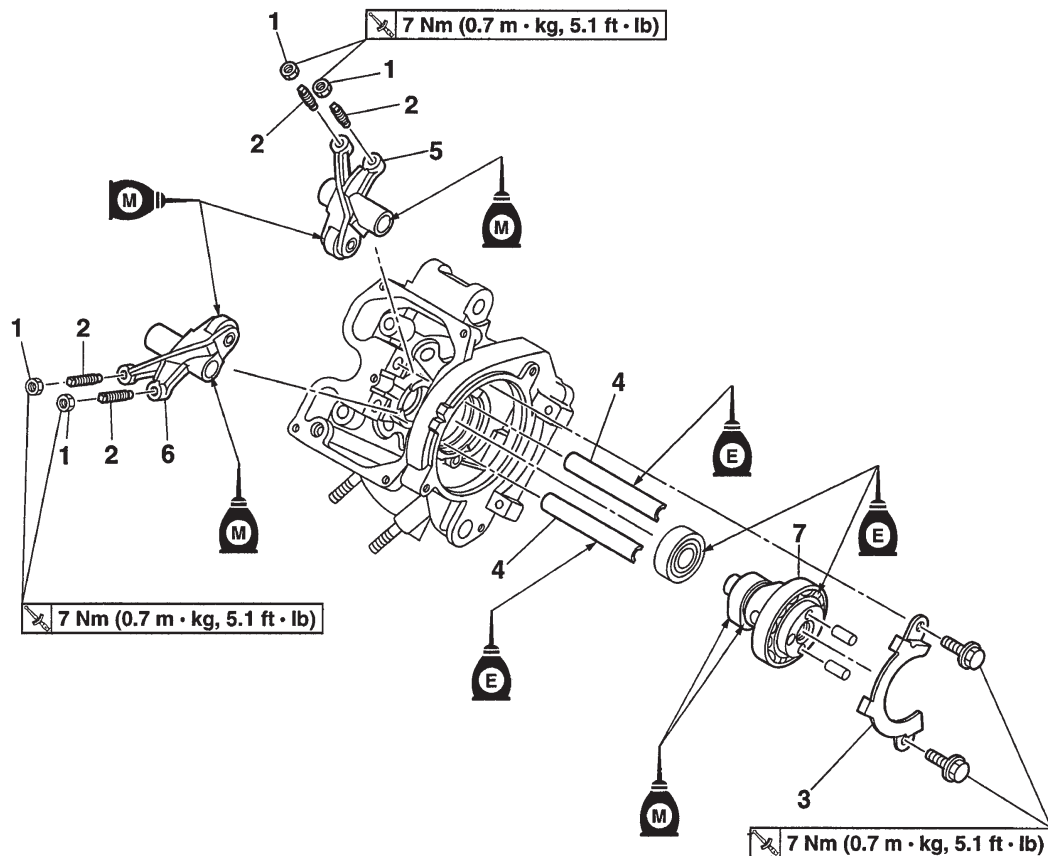

Order	Job/Parts to remove	Q'ty	Remarks
	Cylinder head		
1	Locknut	4	
2	Adjusting screw	4	
3	Camshaft retainer	1	
4	Rocker arm shaft	2	
5	Intake rocker arm	1	
6	Exhaust rocker arm	1	
7	Camshaft	1	
			For installation, reverse the removal procedure.

### CHECKING THE CAMSHAFT

- Check:
  - Camshaft lobes
  - Blue discoloration/pitting/scratches -> Replace the camshaft.
- Measure:
  - Camshaft lobe dimensions "a" and "b"
  - Out of specification -> Replace the camshaft.

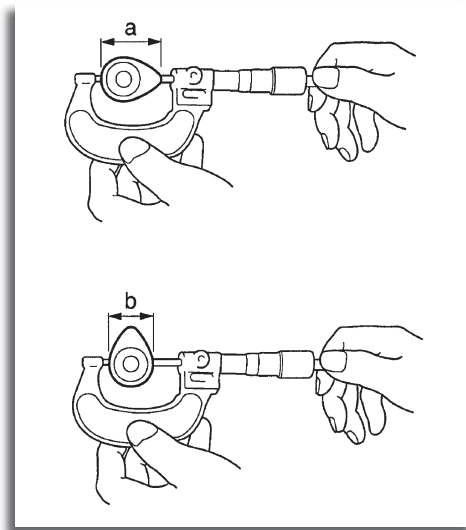

	<p>Camshaft lobe dimensions</p> <p>Intake A 30,225 - 30,325 mm (1,1900 - 1,1939 in)</p> <p>Limit 30,125 mm (1,1860 in)</p> <p>Intake B 25.114 - 25.214 mm</p> <p>Limit 25.014</p> <p>Exhaust A 30.261 - 30.361 mm</p> <p>Limit 30.161</p> <p>Exhaust B 25.172 - 25.272 mm</p> <p>Limit 25.072</p>
--	---

- 3. Check:
  - Camshaft oil passage
  - Obstruction -> Blow out with compressed air.

### CHECKING THE ROCKER ARMS AND ROCKER ARM SHAFTS

The following procedure applies to all of the rocker arms and rocker arm shafts.

- Check:
  - Rocker arm
  - Damagelwear -> Replace.
- Check:
  - Rocker arm shaft
  - Blue discoloration/excessive wear/pitting/scratches -> Replace or check the lubrication system.
- Measure:
  - Rocker arm inside diameter "a"
  - Out of specification -> Replace.

	<p>Rocker arm inside diameter</p> <p>9,985 - 10,000 mm (0,3931 - 0,3937")</p> <p>Limit 10,015 mm (0,3943")</p>
--	--

- Measure:
  - Rocker arm shaft outside diameter "a"
  - Out of specification -> Replace.

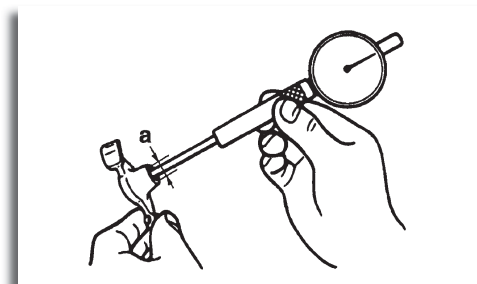

	Rocker arm shaft outside diameter 9,966 - 9,976 mm (0,3924 - 0,3928 in) Limit 9,941 mm (0,3914")
---	---

- Calculate:
  - Rocker-arm-to-rocker-arm-shaft clearance.

NOTE  
 CALCULATE THE CLEARANCE BY SUBTRACTING THE ROCKER ARM SHAFT OUTSIDE DIAMETER FROM THE ROCKER ARM INSIDE DIAMETER.

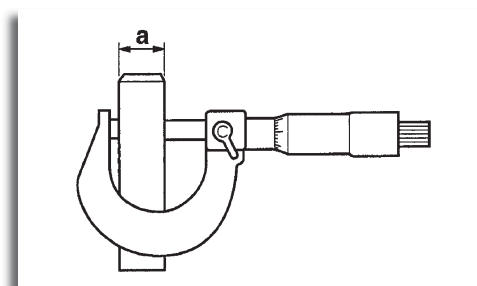

Out of specification -> Replace the defective part(s).

	Rocker-arm-to-rocker-arm-shaft clearance 0,009 - 0,034 mm (0,0004 - 0,0013") Limit 0,074 mm (0,0029")
---	--

## INSTALLING THE CAMSHAFT AND ROCKER ARMS

- Lubricate:
  - Rocker arms
  - Rocker arm shafts

	Recommended lubricant Rocker arm inner surface Molybdenum disulfide oil Rocker arm shaft Engine oil
---	---

- Lubricate:
  - Camshaft

	Recommended lubricant Camshaft Molybdenum disulfide oil Camshaft bearing Engine oil
---	---

## Engine

- Install:
  - Camshaft "1"

NOTE  
MAKE SURE THAT THE CAMSHAFT PROJECTIONS "a" AND HOLE "b" ARE POSITIONED AS SHOWN IN THE ILLUSTRATION.

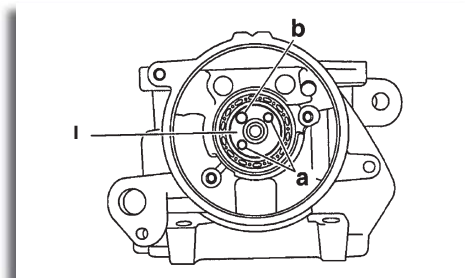

- Install:
  - Rocker arms
  - Rocker arm shafts "1"

NOTE  
MAKE SURE THAT THE CUTOUT "a" IN EACH ROCKER ARM SHAFT IS FACING DOWNWARD AS SHOWN IN THE ILLUSTRATION.

MAKE SURE THE ROCKER ARM SHAFTS (INTAKE AND EXHAUST) ARE COMPLETELY PUSHED INTO THE CYLINDER HEAD.

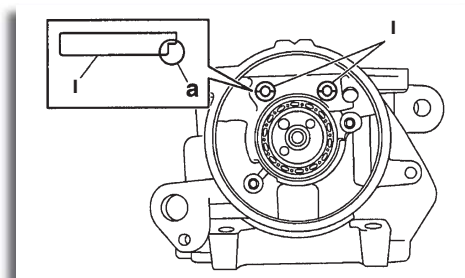



**VALVES AND VALVE SPRINGS**

Removing the valves and valve springs

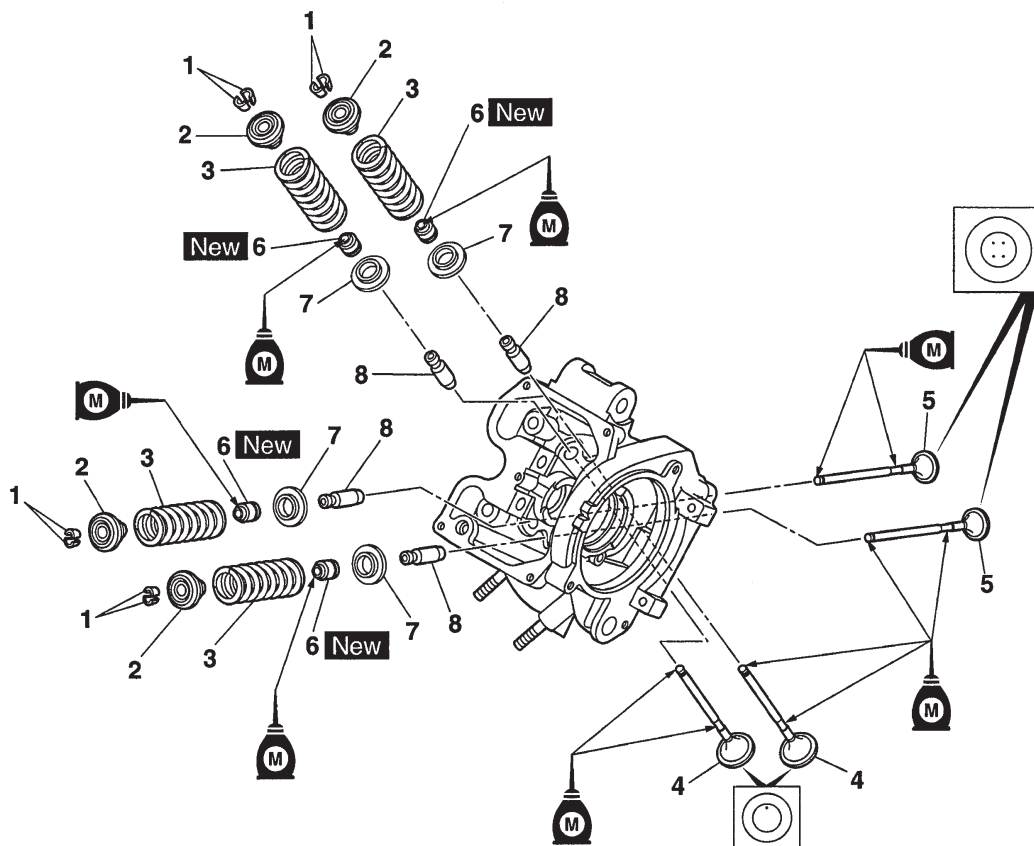

Order	Job/Parts to remove	Q'ty	Remarks
	Cylinder head		
	Rocker arms/Camshaft		
1	Valve cotter	8	
2	Upper spring seat	4	
3	Valve spring	4	
4	Intake valve	2	
5	Exhaust valve	2	
6	Valve stem seal	4	
7	Lower spring seat	4	
8	Valve guide	4	
			For installation, reverse the removal procedure.

## REMOVING THE VALVES

The following procedure applies to all of the valves and related components.

**NOTE**

BEFORE REMOVING THE INTERNAL PARTS OF THE CYLINDER HEAD (E.G., VALVES, VALVE SPRINGS, VALVE SEATS), MAKE SURE THE VALVES PROPERLY SEAL.

- Check:
  - Valve sealing  
Leakage at the valve seat -> Check the valve face, valve seat, and valve seat width.  
Refer to "CHECKING THE VALVE SEATS"

- a) Pour a clean solvent "a" into the intake and exhaust ports.
- b) Check that the valves properly seal.

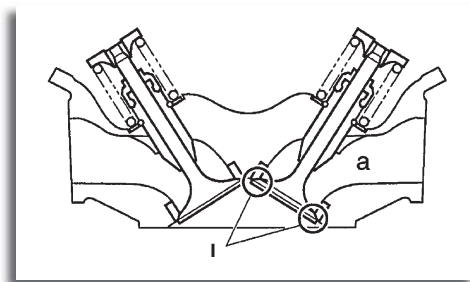

**NOTE**

THERE SHOULD BE NO LEAKAGE AT THE VALVE SEAT "1".

- Remove:
  - Valve cotters "1"

**NOTE**

REMOVE THE VALVE COTTERS BY COMPRESSING THE VALVE SPRING WITH THE VALVE SPRING COMPRESSOR AND THE VALVE SPRING COMPRESSOR ATTACHMENT "2".

	Valve spring compressor 90890-04019 YM-04019 Valve spring compressor attachment 90890-04108 Valve spring compressor adapter 22 mm YM-04108
---	---

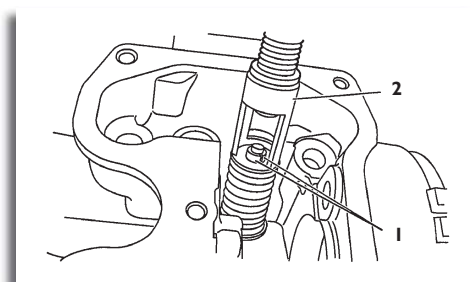

- Remove:
  - Upper spring seat "1"
  - Valve spring "2"
  - Valve "3"
  - Valve stem seal "4"
  - Lower spring seat "5"

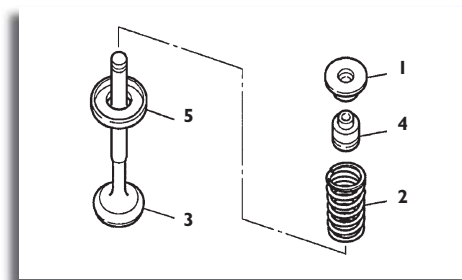

**NOTE**

IDENTIFY THE POSITION OF EACH PART VERY CAREFULLY SO THAT IT CAN BE REINSTALLED IN ITS ORIGINAL PLACE.

**CHECKING THE VALVES AND VALVE GUIDES**

The following procedure applies to all of the valves and valve guides.

- Measure:
  - Valve stem to valve guide clearance
  - Out of specification -> Replace the valve guide.

• Valve-stem-to-valve-guide clearance =  
 Valve guide inside diameter "a" -  
 Valve stem diameter "b"

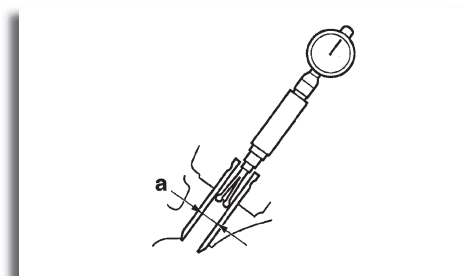

Valve-stem-to-valve-guide clearance  
 (intake)  
 0,010 - 0,037 mm (0,0004 - 0,0015 in)  
 Limit  
 0,080 mm (0,0032 in)  
 Valve stem to valve guide clearance  
 (exhaust)  
 0,025 - 0,052 mm (0,0010 - 0,0020 in)  
 Limit  
 0,100 mm (0,0039 in)

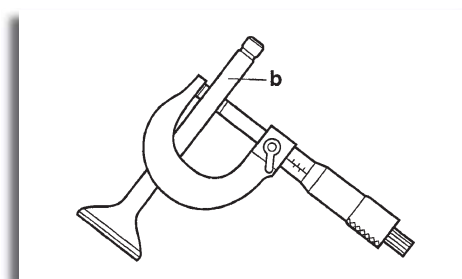

- Replace:
  - Valve guide

**NOTE**

TO EASE VALVE GUIDE REMOVAL AND INSTALLATION, AND TO MAINTAIN THE CORRECT FIT, HEAT THE CYLINDER HEAD TO 100 °C (212 °F) IN AN OVEN.

- a) Remove the valve guide with the valve guide remover "1".
- b) Install the new valve guide with the valve guide installer "2" and valve guide remover "1".



Valve guide position (Intake)  
17,0 - 17,4 mm (0,669 - 0,685 in)

Valve guide position (exhaust)  
14,0 - 14,4 mm (0,551 - 0,567 in)

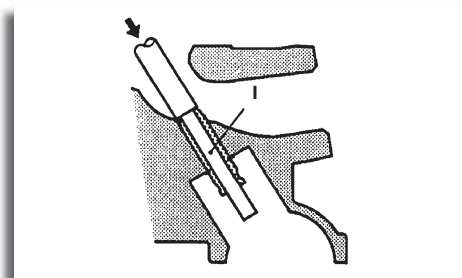

*a. Valve guide position*

- c) After installing the valve guide, bore the valve guide with the valve guide reamer "3" to obtain the proper valve stem to valve guide clearance.

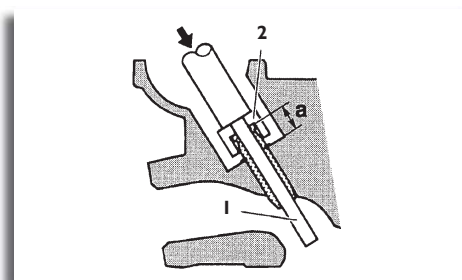

**NOTE**

AFTER REPLACING THE VALVE GUIDE, REFACE THE VALVE SEAT.



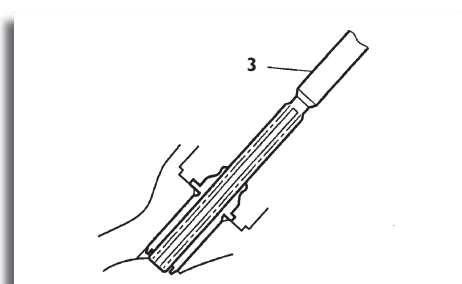

- Valve guide remover  
(Ø 4,5)  
90890-04116
- Valve guide remover  
(Ø 4,5 mm)  
YM-04116
- Valve guide installer  
(Ø 4,5)  
90890-04117
- Valve guide installer  
(Ø 4,5 mm)  
YM-04117
- Valve guide reamer  
(Ø 4,5)  
90890-04118
- Valve guide reamer  
(Ø 4,5 mm)  
YM-04118

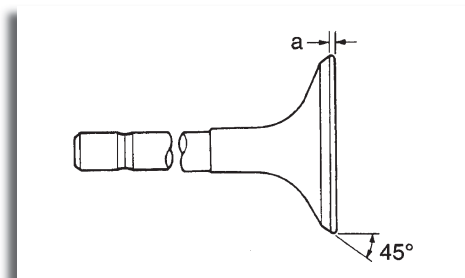

- Eliminate:
  - Carbon deposits  
(from the valve face and valve seat)
- Check:
  - Valve face  
Pitting/wear -> Grind the valve face.
  - Valve stem end  
Mushroom chape or diameter larger than the body of the valve stem -> Replace the valve.
- Measure:
  - Valve margin thickness D "a"  
Out of specification -> Replace the valve.



	Valve margin thickness D (intake)
	0,50 - 0,90 mm (0,0197 - 0,0354 in)
	Valve margin thickness D (exhaust)
	0,50 - 0,90 mm (0,0197 - 0,0354 in)

- Measure:
  - Valve stem runout  
Out of specification -> Replace the valve.

NOTE  
WHEN INSTALLING A NEW VALVE, ALWAYS REPLACE THE  
VALVE GUIDE.

IF THE VALVE IS REMOVED OR REPLACED, ALWAYS REPLACE  
THE VALVE STEM SEAL.

	Valve stem runout
	0,010 mm (0,0004")

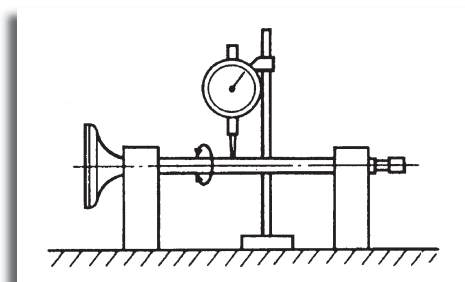

## CHECKING THE VALVE SEATS

The following procedure applies to all of the valves and valve seats.

- Eliminate:
  - Carbon deposits  
(from the valve face and valve seat)
- Check:
  - Valve seat  
Pitting/wear -> Replace the cylinder head.
- Measure:
  - Valve seat width C "a"  
Out of specification -> Replace the cylinder head.

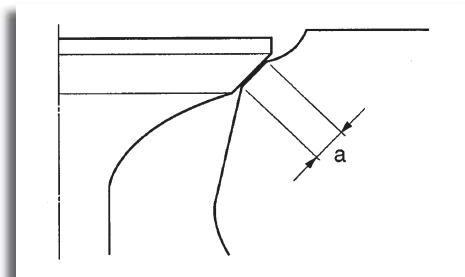

	Valve seat width C
	(intake)
	0,90 - 1,10 mm (0,0354 - 0,0433 in)
	Valve seat width C
(exhaust)	
0,90 - 1,10 mm (0,0354 - 0,0433 in)	

- a) Apply Mechanic's blueing dye (Dykem) "b" onto the valve face.
- b) Install the valve into the cylinder head.
- c) Press the valve through the valve guide and onto the valve seat to make a clear impression.
- d) Measure the valve seat width.

**NOTE**  
WHERE THE VALVE SEAT AND VALVE FACE CONTACTED ONE ANOTHER, THE BLUEING WILL HAVE BEEN REMOVED.

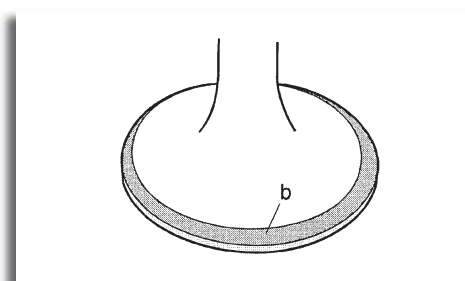

- Lap:
  - Valve face
  - Valve seat

**NOTE**  
AFTER REPLACING THE CYLINDER HEAD OR REPLACING THE VALVE AND VALVE GUIDE, THE VALVE SEAT AND VALVE FACE SHOULD BE LAPPED.

- a) Apply a coarse lapping compound "a" to the valve face.

**CAUTION**  
DO NOT LET THE LAPPING COMPOUND ENTER THE GAP BETWEEN THE VALVE STEM AND THE VALVE GUIDE.

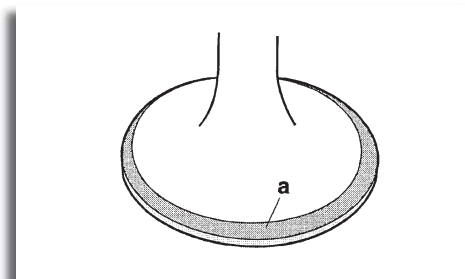

- b) Apply molybdenum disulfide oil onto the valve stem.
- c) Install the valve into the cylinder head.
- d) Turn the valve until the valve face and valve seat are evenly polished, then clean off all of the lapping compound.

## NOTE

FOR THE BEST LAPPING RESULTS, LIGHTLY TAP THE VALVE SEAT WHILE ROTATING THE VALVE BACK AND FORTH BETWEEN YOUR HANDS.

- e) Apply a fine lapping compound to the valve face and repeat the above steps.
- f) After every lapping procedure, be sure to clean off all of the lapping compound from the valve face and valve seat.
- g) Apply Mechanic's blueing dye (Dykem) "b" onto the valve face.
- h) Install the valve into the cylinder head.
- i) Press the valve through the valve guide and onto the valve seat to make a clear impression.
- j) Measure the valve seat width "c" again. If the valve seat width is out of specification, reface and lap the valve seat.

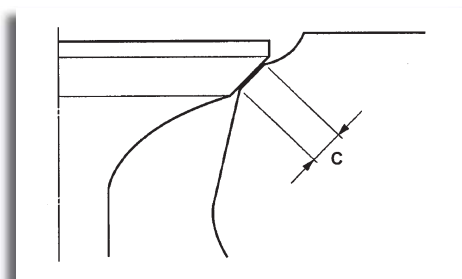
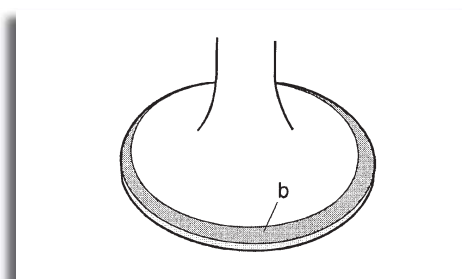
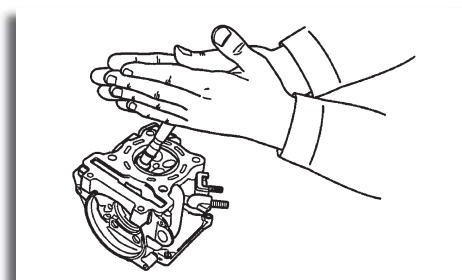
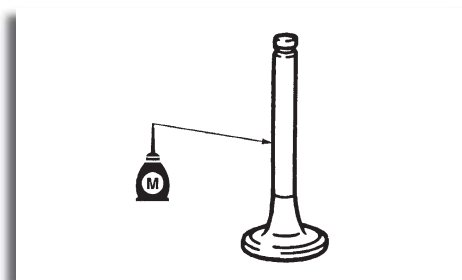

## CHECKING THE VALVE SPRINGS

The following procedure applies to all of the valve springs.

• Measure:

- Valve spring free length "a"
- Out of specification -> Replace the valve spring.



Free length (intake)  
41,71 mm (1,64 in)  
Limit  
39,62 mm (1,56 in)  
Free length (exhaust)  
41,71 mm (1,64 in)  
Limit  
39,62 mm (1,56 in)

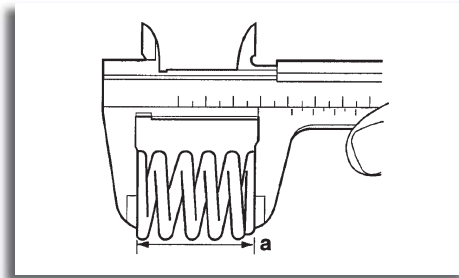

• Measure:

- Compressed valve spring force "a"
- Out of specification -> Replace the valve spring.



Installed compression spring  
force (intake)  
140 - 162 N (31,47 - 36,42 lbf)  
(14,28 - 16,52 kgf)  
Installed compression spring  
force (exhaust)  
140 - 162 N (31,47 - 36,42 lbf)  
(14,28 - 16,52 kgf)  
Installed length (intake)  
35,30 mm (1,39 in)  
Installed length (exhaust)  
35,30 mm (1,39 in)

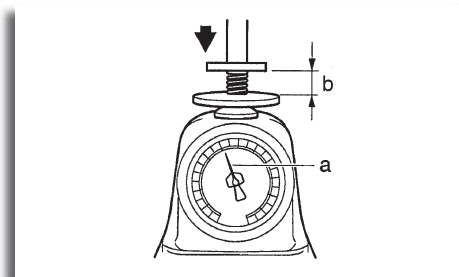

*b. Installed length*

• Measure:

- Valve spring tilt "a"
- Out of specification -> Replace the valve spring.



Spring tilt (intake)  
2,5°/1,8 mm  
Spring tilt (exhaust)  
2,5°/1,8 mm

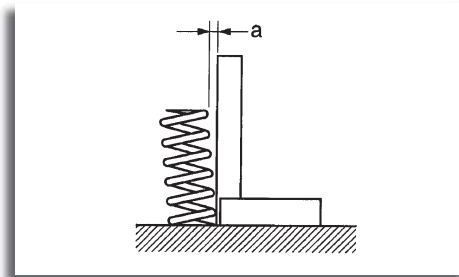



### INSTALLING THE VALVES

The following procedure applies to all of the valves and related components.

- Deburr:
  - Valve stem end  
(with an oil stone)
- Lubricate:
  - Valve stem "1"
  - Valve stem seal "2" - **New**  
(with the recommended lubricant)

	Recommended lubricant Molybdenum disulfide oil
---	---

- Install:
  - Lower spring seat "1"
  - Valve stem seal "2" - **New**
  - Valve "3"
  - Valve spring "4"
  - Upper spring seat "5"  
(into the cylinder head).

**NOTE**  
MAKE SURE EACH VALVE IS INSTALLED IN ITS ORIGINAL PLACE.

INSTALL THE VALVE SPRINGS WITH THE LARGER PITCH "a"  
FACING UP.

*b. Smaller pitch*

- Install:
  - Valve cotters "1"

**NOTE**  
INSTALL THE VALVE COTTERS BY COMPRESSING THE VALVE SPRING WITH THE VALVE SPRING COMPRESSOR AND THE VALVE SPRING COMPRESSOR ATTACHMENT "2".

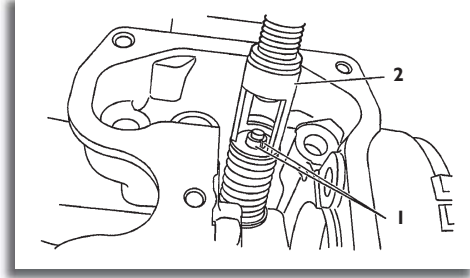
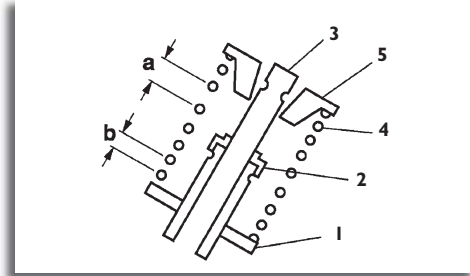
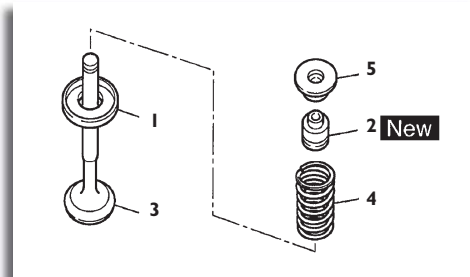
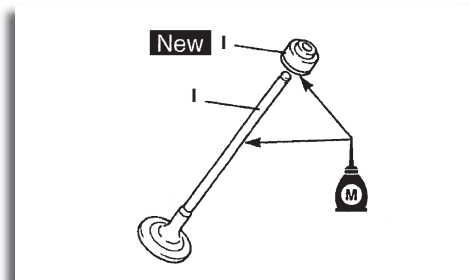
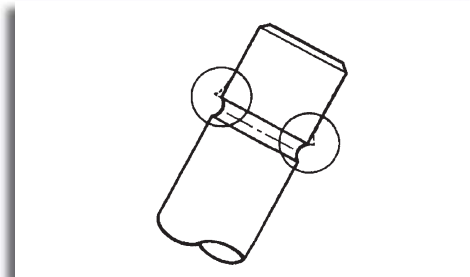

## Engine



Valve spring compressor  
90890-04019  
YM-04019

Valve spring compressor attachment  
90890-04108

Valve spring compressor adapter  
22 mm  
YM-04108

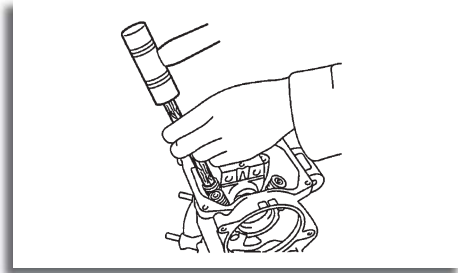

- To secure the valve cotters onto the valve stem, lightly tap the valve tip with a soft-face hammer.

**CAUTION**  
HITTING THE VALVE TIP WITH EXCESSIVE FORCE COULD  
DAMAGE THE VALVE.

**CYLINDER AND PISTON**

Removing the cylinder and piston

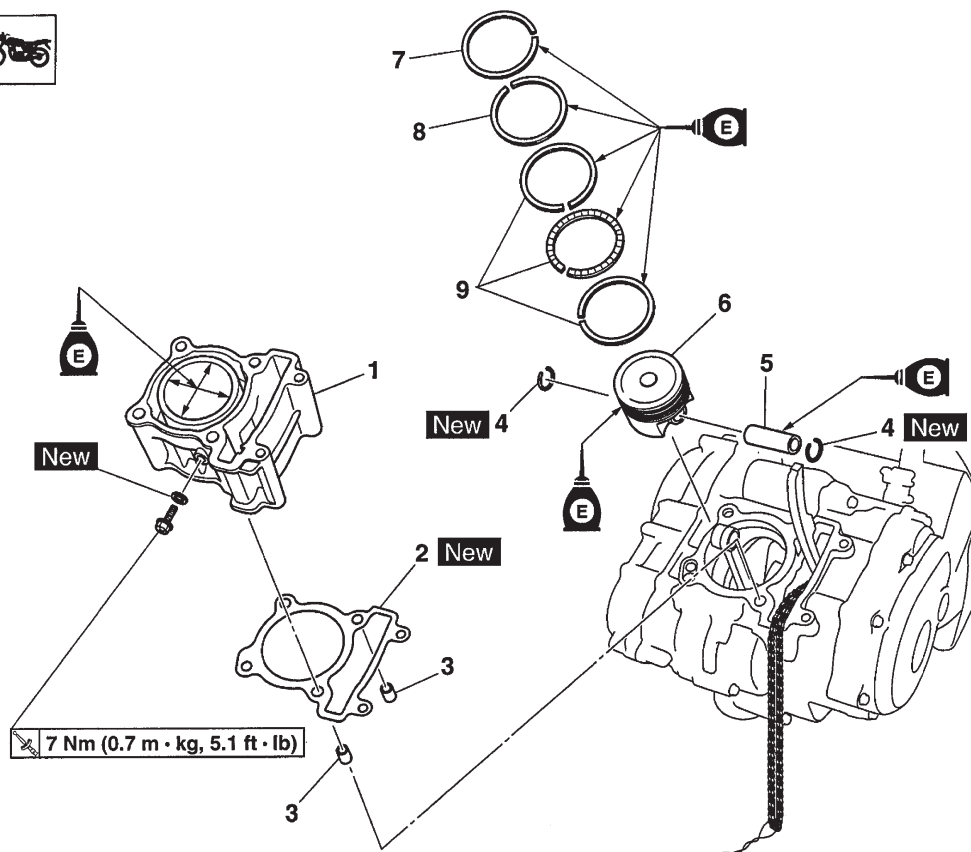

Order	Job/Parts to remove	Q'ty	Remarks
	Cylinder head		
1	Cylinder	1	
2	Cylinder gasket	1	
3	Dowel pin	2	
4	Piston pin clip	2	
5	Piston pin	1	
6	Piston	1	
7	Top ring	1	
8	2nd ring	1	
9	Oil ring	1	
			For installation, reverse the removal procedure.

## REMOVING THE PISTON

- Remove:
  - Piston pin clips "1"
  - Piston pin "2"
  - Piston "3"

**CAUTION**  
DO NOT USE A HAMMER TO DRIVE THE PISTON PIN OUT.

**NOTE**  
BEFORE REMOVING THE PISTON PIN CLIP, COVER THE CRANKCASE OPENING WITH A CLEAN RAG TO PREVENT THE PISTON PIN CLIP FROM FALLING INTO THE CRANKCASE.

BEFORE REMOVING THE PISTON PIN, DEBURR THE PISTON PIN CLIP GROOVE AND THE PISTON PIN BORE AREA. IF BOTH AREAS ARE DEBURRED AND THE PISTON PIN IS STILL DIFFICULT TO REMOVE, REMOVE IT WITH THE PISTON PIN PULLER SET "4".

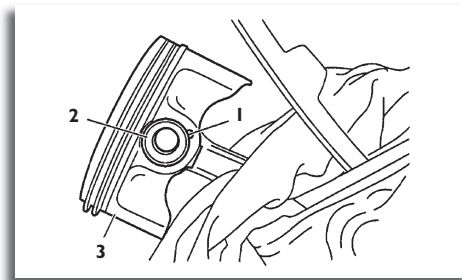

	Piston pin puller set 90890-01304 Piston pin puller YU-01304
---	---

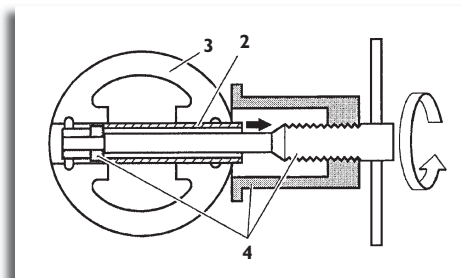

- Remove:
  - Top ring
  - 2nd ring
  - Oil ring.

**NOTE**  
WHEN REMOVING A PISTON RING, OPEN THE END GAP WITH YOUR FINGERS AND LIFT THE OTHER SIDE OF THE RING OVER THE PISTON CROWN.

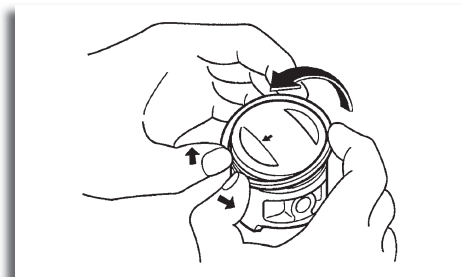

**CHECKING THE CYLINDER AND PISTON**

- Check:
  - Piston wall
  - Cylinder wall  
Vertical scratches -> Replace the cylinder, and replace the piston and piston rings as a set.
- Measure:
  - Piston-to-cylinder clearance

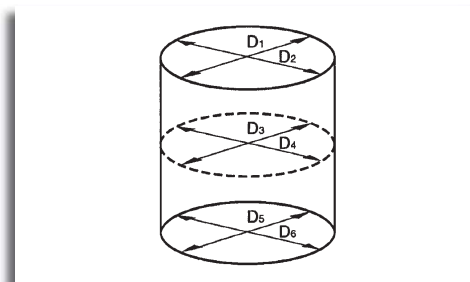

a) Measure cylinder bore "C" with the cylinder

NOTE  
MEASURE CYLINDER BORE "C" BY TAKING SIDE-TO-SIDE AND FRONT-TO-BACK MEASUREMENTS OF THE CYLINDER. THEN, FIND THE AVERAGE OF THE MEASUREMENTS.

	Bore 52,000 - 52,010 mm (2,0472 - 2,0476 in) Taper limit 0,050 mm (0,0020 in) Out of round limit 0,005 mm (0,0002 in)
--	---

"C"= maximum of D1 - D2  "T"= maximum of D1 or D2 - maximum of D5 or D6  "R"= maximum of D1, D3 or D5 - maximum de D2, D4 or D6
---

- b) If out of specification, replace the cylinder, and replace the piston and piston rings as a set.
- c) Measure piston skirt diameter D "a" with the micrometer.

*b. 5.0 mm (0.20 in) from the bottom edge of the piston*

	Piston Diameter D 51,962 - 51,985 mm (2,0457 - 2,0466")
--	---

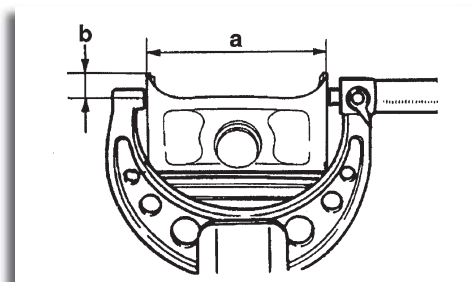

## Engine

d) If out of specification, replace the piston and piston rings as a set.

e) Calculate the piston-to-cylinder clearance with the following formula.

$$\text{Piston-to-cylinder clearance} = \text{Cylinder bore "C"} - \text{Piston skirt diameter "D"}$$



Piston-to-cylinder clearance  
0,015 - 0,048 mm (0,0006 - 0,0019 in)  
Limit  
0,15 mm (0,0059 in)

f) If out of specification, replace the cylinder, and replace the piston and piston rings as a set.

## CHECKING THE PISTON RINGS

- Measure:
  - Piston ring side clearance
  - Out of specification -> Replace the piston and piston rings as a set.

### NOTE

BEFORE MEASURING THE PISTON RING SIDE CLEARANCE, ELIMINATE ANY CARBON DEPOSITS FROM THE PISTON RING GROOVES AND PISTON RINGS.



Piston ring  
Top ring  
Ring side clearance  
0,030 - 0,065 mm (0,0012 - 0,0026 in)  
Limit  
0,100 mm (0,0039 in)  
2nd ring  
Ring side clearance  
0,020 - 0,055 mm (0,0008 - 0,0022 in)  
Limit  
0,100 mm (0,0039 in)

- Install:
  - Piston ring  
(into the cylinder).

NOTE  
LEVEL THE PISTON RING INTO THE CYLINDER WITH THE  
PISTON CROWN.

a. 40 mm (1,57")

3. Measure:
- Piston ring end gap  
Out of specification -> Replace the piston ring.

NOTE  
THE OIL RING EXPANDER SPACER END GAP CANNOT BE  
MEASURED. IF THE OIL RING RAIL GAP IS EXCESSIVE, REPLA-  
CE ALL THREE PISTON RINGS.

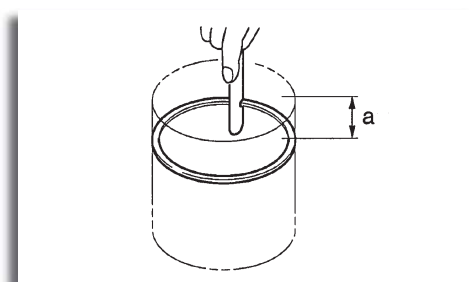

	Piston ring
	Oil ring
	End gap (installed)
	0,10 - 0,25 mm (0,0039 - 0,0098 in)
	Limit
	0,50 mm (0,0197 in)
	2nd ring
	End gap (installed)
	0,10 - 0,25 mm (0,0039 - 0,0098 in)
	Limit
	0,60 mm (0,0236 in)
	Oil ring
	End gap (installed)
	0,20 - 0,70 mm (0,0079 - 0,0276 in)

## CHECKING THE PISTON PIN

- Check:
  - Piston pin  
Blue discoloration/grooves -> Replace the piston pin and then check the lubrication system.
- Measure:
  - Piston pin outside diameter "a"  
Out of specification -> Replace the piston pin.

## Engine



Piston pin outside diameter  
13,995 - 14,000 mm  
(0,5510 - 0,5512 in)  
Limit 13,975 mm (0,5502 in)

• Measure:

- Piston pin bore diameter "b"  
Out of specification -> Replace the piston.

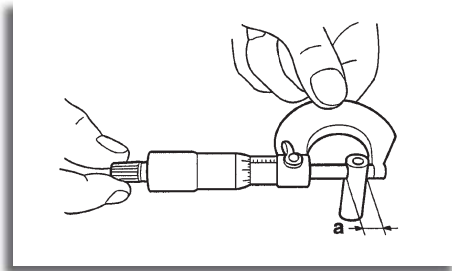

Piston pin bore inside diameter  
14,002 - 14,013 mm  
(0,5513 - 0,5517 in)  
Limit  
14,043 mm (0,5529 in)

• Calculate:

- Piston pin-to-piston-pin-bore clearance  
Out of specification -> Replace the piston pin  
and piston as a set.

- Piston-pin-to-piston-pin-bore clearance =  
Piston pin bore diameter "b" -  
Piston pin outside diameter "a"

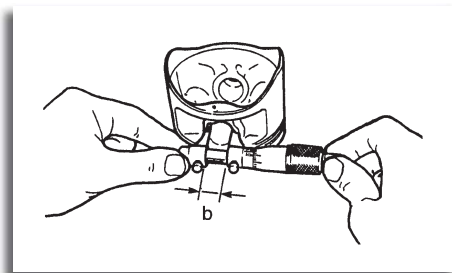

Piston-pin-to-piston-pin-bore clearance  
0,002 - 0,018 mm (0,0001 - 0,0007 in)  
Limit  
0,068 mm (0,0027 in)

## INSTALLING THE PISTON AND CYLINDER

• Install:

- Top ring "1"
- 2nd ring "2"
- Oil ring expander "3"
- Lower oil ring rail "4"
- Upper oil ring rail "5"

NOTE

BE SURE TO INSTALL THE PISTON RINGS SO THAT THE MANUFACTURER MARKS OR NUMBERS FACE UP.



- Install:
  - Piston "1"
  - Piston pin "2"
  - Piston pin clips "3" - **New**

NOTE  
APPLY ENGINE OIL TO THE PISTON PIN.

MAKE SURE THE ARROW MARK "a" ON THE PISTON POINTS TOWARDS THE EXHAUST SIDE OF THE CYLINDER.

BEFORE INSTALLING THE PISTON PIN CLIPS, COVER THE CRANKCASE OPENING WITH A CLEAN RAG TO PREVENT THE CLIPS FROM FALLING INTO THE CRANKCASE.

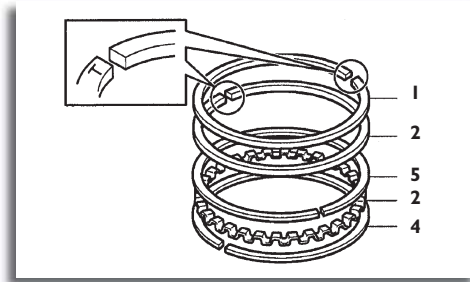

- Lubrique:
  - Lubricate:
    - Piston
    - Piston rings
    - Cylinder (with the recommended lubricant)

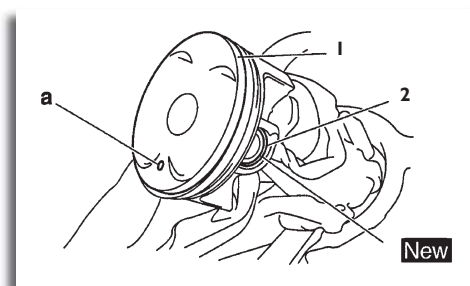

	<p>Recommended lubricant Engine oil</p>
---	---

- Offset:
  - Piston ring end gapsn.

- a. Top ring
- b. Upper oil ring rail
- c. Oil ring expander
- d. Lower oil ring rail
- e. 2nd ring
- f. 20 mm (0.79 in)
- A. Intake side

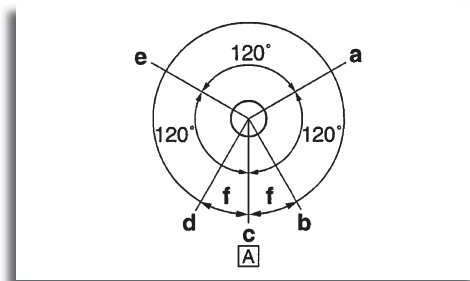

- Install:
  - Dowel pins
  - Cylinder head gasket - **New**
  - Cylinder "1"

NOTE  
WHILE COMPRESSING THE PISTON RINGS WITH ONE HAND, INSTALL THE CYLINDER WITH THE OTHER HAND.

PASS THE TIMING CHAIN AND TIMING CHAIN GUIDE (INTAKE SIDE) THROUGH THE TIMING CHAIN CAVITY.

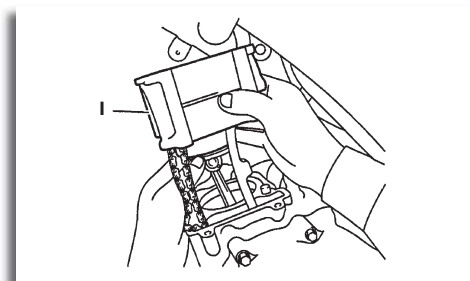

**GENERATOR AND STARTER CLUTCH**

Removing the generator and starter clutch

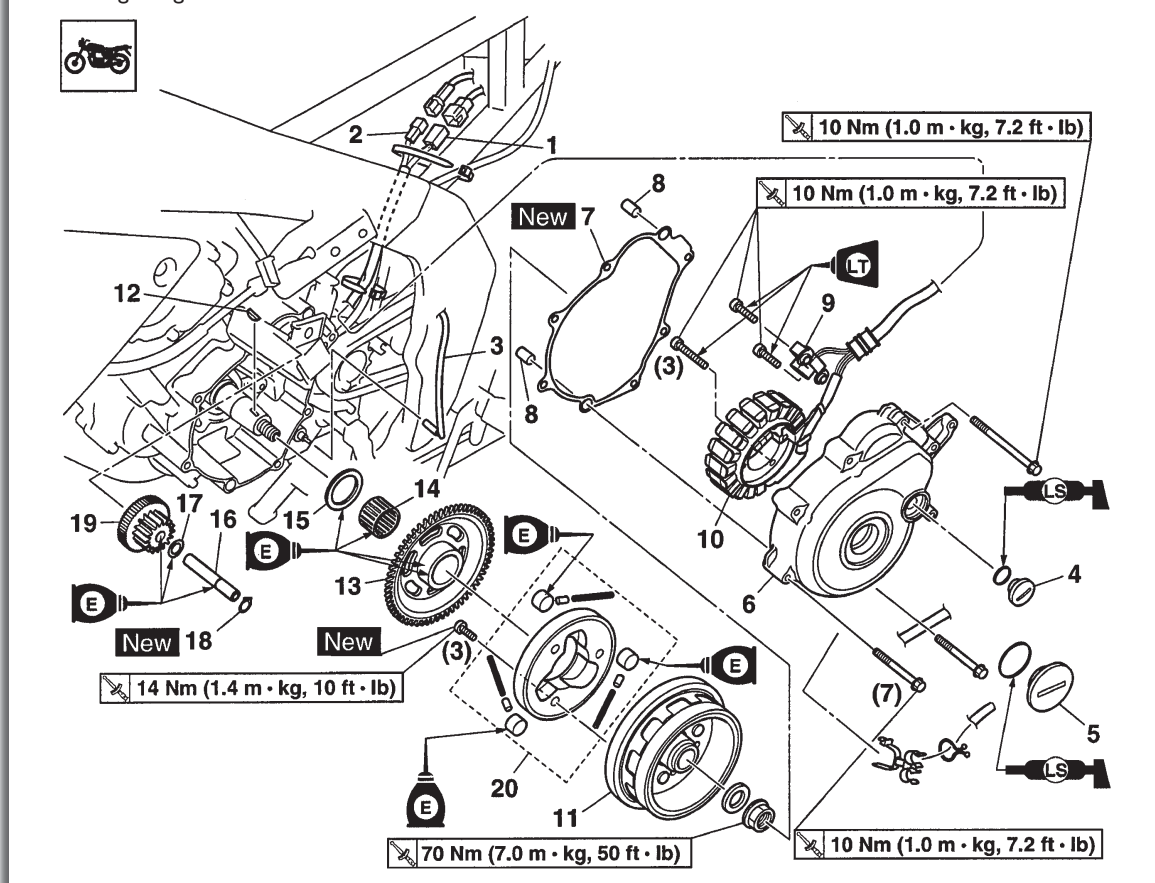

Order	Job/Parts to remove	Q'ty	Remarks
	Engine oil		
	Drive sprocket cover		
1	Stator coil coupler	1	Disconnect
2	Crankshaft position sensor coupler	1	Disconnect
3	Neutral switch lead connector	1	Disconnect
4	Timing mark accessing screw	1	
5	Crankshaft end accessing screw	1	
6	Generator cover	1	
7	Generator cover gasket	1	
8	Dowel pin	2	
9	Crankshaft position sensor	1	
10	Stator coil	1	
11	Generator rotor	1	
12	Wodruff key	1	

**GENERATOR AND STARTER CLUTCH**

Removing the generator and starter clutch

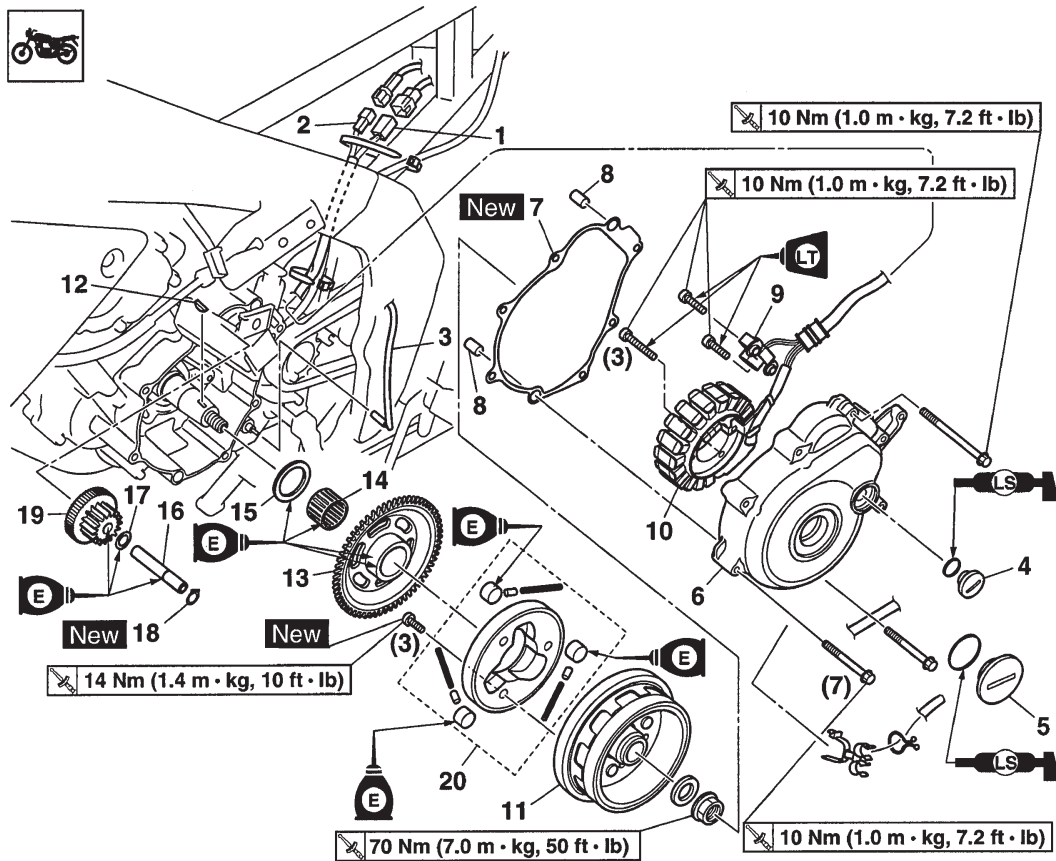

Order	Job/Parts to remove	Q'ty	Remarks
13	Starter clutch gear	1	
14	Bearing	1	
15	Washer	1	
16	Starter clutch idle gear shaft	1	
17	Washer	1	
18	Circlip	1	
19	Starter clutch idle gear	1	
20	Starter clutch assembly	1	
			For installation, reverse the removal procedure.

**REMOVING THE GENERATOR**

- Remove:
  - Generator rotor nut “1”
  - Washer

**NOTE**  
 WHILE HOLDING THE GENERATOR ROTOR “2” WITH THE SHEAVE HOLDER “3”, LOOSEN THE GENERATOR ROTOR NUT.

DO NOT ALLOW THE SHEAVE HOLDER TO TOUCH THE PROJECTION ON THE GENERATOR ROTOR.

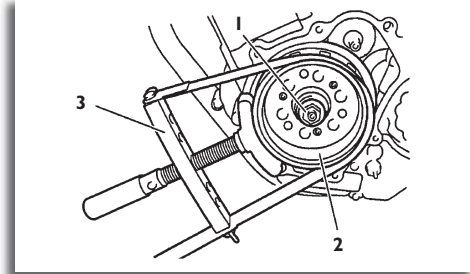

	Sheave holder 90890-01701 Primary clutch holder YS-01880-A
---	---

- Remove:
  - Generator rotor “1”  
 (with the flywheel puller “2”)
  - Woodruff key

**CAUTION**  
 TO PROTECT THE END OF THE CRANKSHAFT, PLACE AN APPROPRIATE SIZED SOCKET BETWEEN THE FLYWHEEL PULLER SET CENTER BOLT AND THE CRANKSHAFT.

**NOTE**  
 MAKE SURE THE FLYWHEEL PULLER IS CENTERED OVER THE GENERATOR ROTOR.

	Flywheel puller 90890-01362 Heavy duty puller YU-33270-B
---	---

### REMOVING THE STARTER CLUTCH

- Remove:
  - Starter clutch bolts "1"

**NOTE**  
WHILE HOLDING THE GENERATOR ROTOR "2" WITH THE SHEAVE HOLDER "3", REMOVE THE STARTER CLUTCH BOLTS.

DO NOT ALLOW THE SHEAVE HOLDER TO TOUCH THE PROJECTION ON THE GENERATOR ROTOR.

	<p>Sheave holder 90890-01701 Primary clutch holder YS-01880-A</p>
---	---

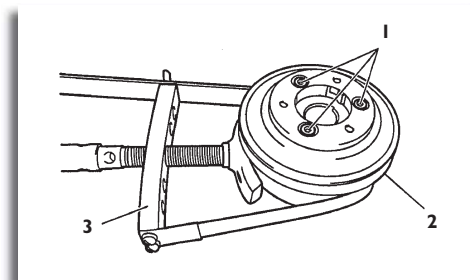
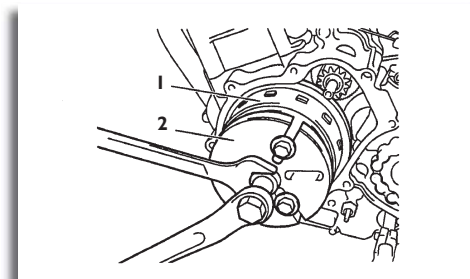

### CHECKING THE STARTER CLUTCH

- Check:
  - Starter clutch rollers "1"
  - Starter clutch spring caps "2"
  - Starter clutch springs "3"
  - Damagelwear -> Replace the starter clutch assembly.
- Check:
  - Starter clutch idle gear
  - Starter clutch gear
  - Burrs/chips/roughness/wear -> Replace the defective part(s).
- Check:
  - Starter clutch gear contacting surfaces
  - Damagelpitting/wear -> Replace the starter clutch gear.
- Check:
  - Starter clutch operation

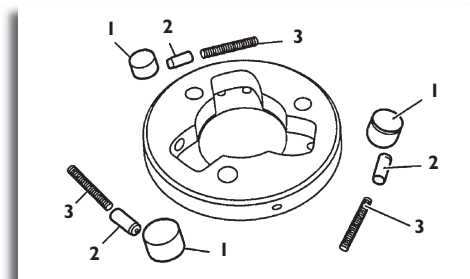

a) Install the starter clutch gear "1" onto the starter clutch and hold the generator rotor.

b) When turning the starter clutch gear clockwise "A", the starter clutch and the starter clutch gear should engage, otherwise the starter clutch is faulty and must be replaced.

c) When turning the starter clutch gear counterclockwise "B", it should turn freely, otherwise the starter clutch is faulty and must be replaced.

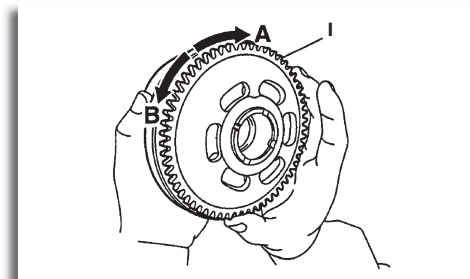

### INSTALLING THE STARTER CLUTCH

- Install:
  - Starter clutch assembly
  - Starter clutch bolts "1" - **New**

	Starter clutch bolt 14 Nm (1,4 m-kg, 10 ft-lb)
---	---

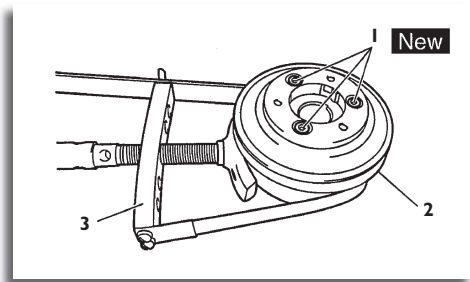

**NOTE**  
 WHILE HOLDING THE GENERATOR ROTOR "2" WITH THE SHEAVE HOLDER "3", TIGHTEN THE STARTER CLUTCH BOLTS.

DO NOT ALLOW THE SHEAVE HOLDER TO TOUCH THE PROJECTION ON THE GENERATOR ROTOR.

STAKE THE END "a" OF EACH STARTER CLUTCH BOLT.

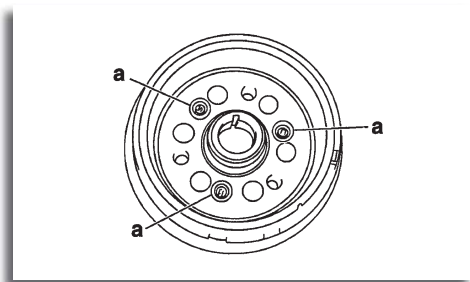

	Sheave holder 90890-01701 Primary clutch holder YS-01880-A
---	---

### INSTALLING THE GENERATOR

- Install:
  - Woodruff key
  - Generator rotor
  - Washer
  - Generator rotor nut

**NOTE**  
 CLEAN THE TAPERED PORTION OF THE CRANKSHAFT AND THE GENERATOR ROTOR HUB.

WHEN INSTALLING THE GENERATOR ROTOR, MAKE SURE THE WOODRUFF KEY IS PROPERLY SEALED IN THE KEYWAY OF THE CRANKSHAFT.

- Tighten:
  - Generator rotor nut "1"

	Generator rotor nut 70 Nm (7,0 m-kg, 50 ft-lb)
---	---

NOTE  
WHILE HOLDING THE GENERATOR ROTOR "2" WITH THE SHEAVE HOLDER "3", TIGHTEN THE GENERATOR ROTOR NUT.

DO NOT ALLOW THE SHEAVE HOLDER TO TOUCH THE PROJECTION ON THE GENERATOR ROTOR.

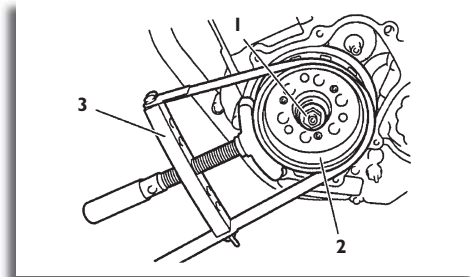

	<p>Sheave holder 90890-01701 Primary clutch holder YS-01880-A</p>
--	---

- Apply:
  - Sealant  
(onto the crankshaft position sensor/stator assembly lead grommet)

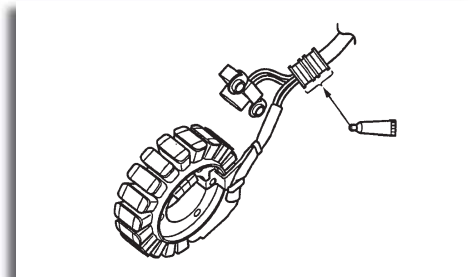

	<p>Yamaha bond n° 1215 90890-85505 (Three Bond n° 1215®)</p>
--	--

- Install:
  - Generator cover

	<p>Generator cover bolt 10 Nm (1,0 m·kg, 7,2 ft·lb)</p>
--	---

NOTE  
TIGHTEN THE GENERATOR COVER BOLTS IN THE PROPER TIGHTENING SEQUENCE AS SHOWN.

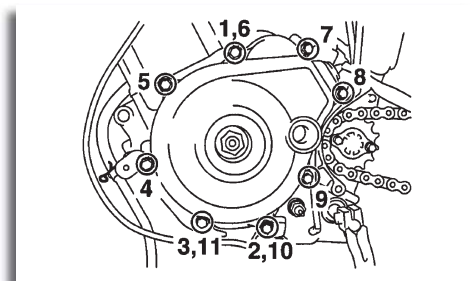

**ELECTRIC STARTER**

Removing the starter motor



10 Nm (1.0 m · kg, 7.2 ft · lb)

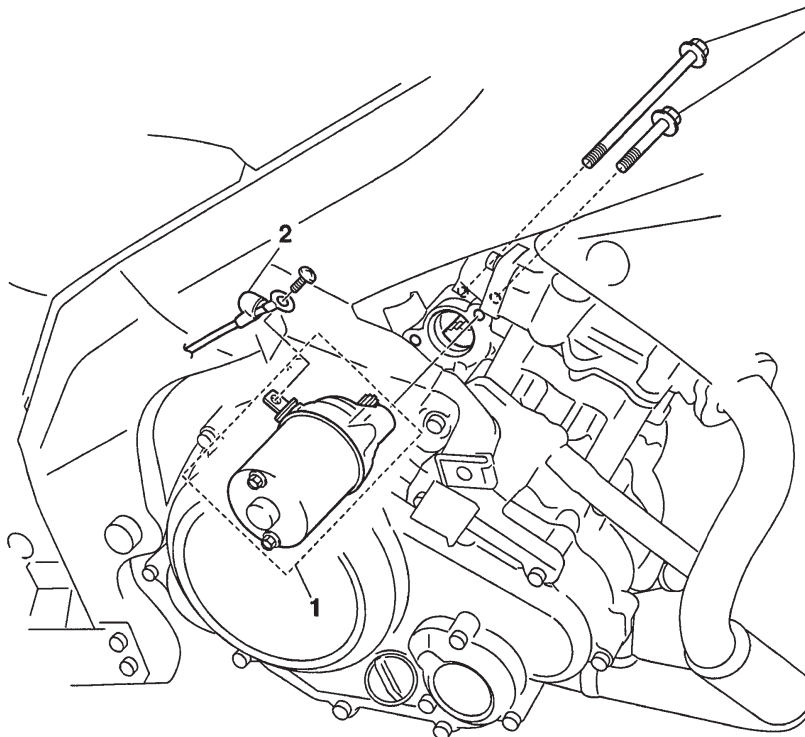

Order	Job/Parts to remove	Q'ty	Remarks
1	Starter motor	1	
2	Starter motor lead	1	Disconnect
			For installation, reverse the removal procedure.



**ELECTRIC STARTER**

Disassembling the starter motor

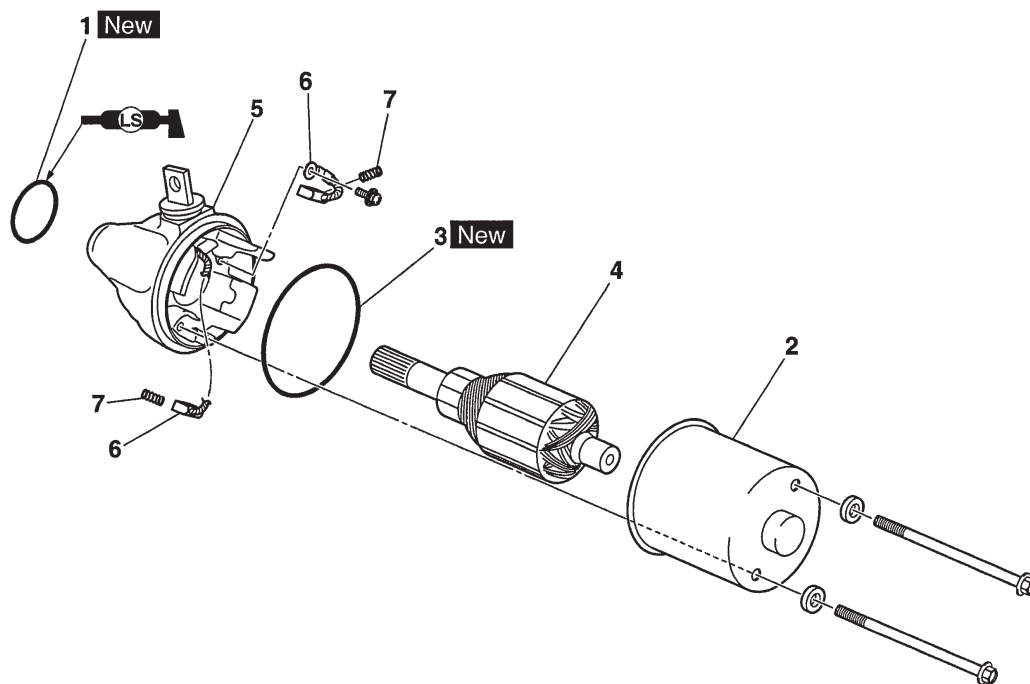

Order	Job/Parts to remove	Q'ty	Remarks
1	O-ring	1	
2	Starter motor yoke	1	
3	O-ring	1	
4	Commutator	1	
5	Starter motor front cover/brush holder set	1	
6	Brush	2	
7	Brush spring	2	
			For installation, reverse the removal procedure.

**CHECKING THE STARTER MOTOR**

- Check:
  - Commutator  
Dirt -> Clean with 600 grit sandpaper.
- Measure:
  - Commutator diameter "a"  
Out of specification -> Replace the starter motor.

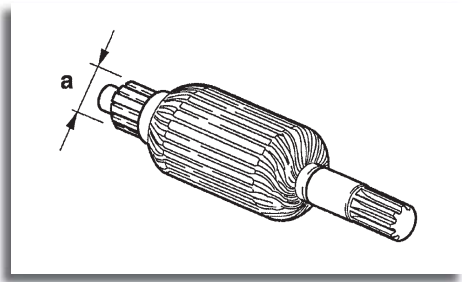

	Limit 16,6 mm (0,65")
--	--------------------------

- Mida:
  - Mica undercut "a"  
Out of specification -> Scrape the mica to the proper measurement with a hacksaw blade that has been grounded to fit the commutator.

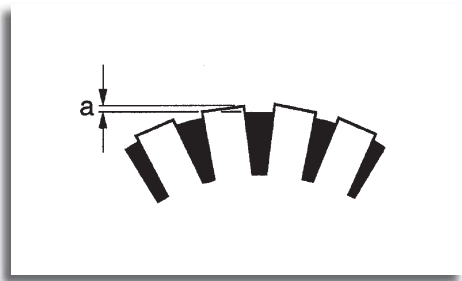

	Mica undercut (depth) 1,35 mm (0,05")
--	--

NOTE  
THE MICA OF THE COMMUTATOR MUST BE UNDERCUT TO ENSURE PROPER OPERATION OF THE COMMUTATOR.

- Measure:
  - Armature assembly resistances (commutator and insulation)  
Out of specification -> Replace the starter motor.

a) Measure the armature assembly resistances with the pocket tester.

	Pocket tester 90890-03112 Analog pocket tester YU-03112-C
--	--

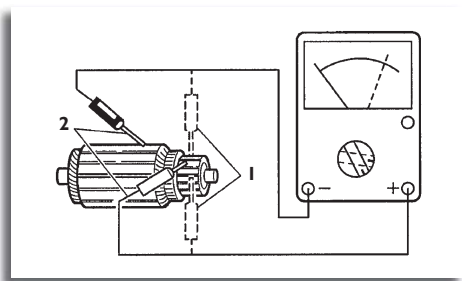

	Armature coil Commutator resistance "1" 0,0315 - 0,0385 Ω Insulation resistance "2" Above 1M Ω
--	--

b) If any resistance is out of specification, replace the starter motor.

- Measure:
  - Brush length "a"
  - Out of specification -> Replace the starter motor front cover/brush holder set.

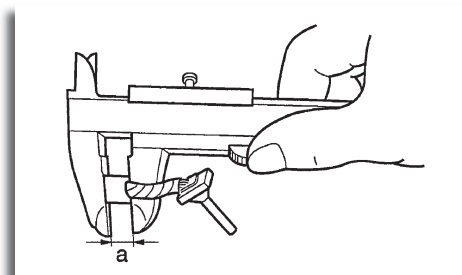
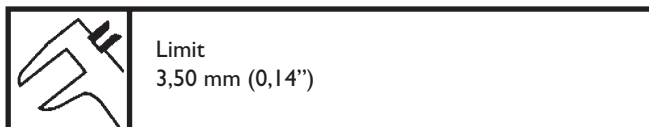

- Measure:
  - Brush spring force
  - Out of specification -> Replace the brush springs as a set.

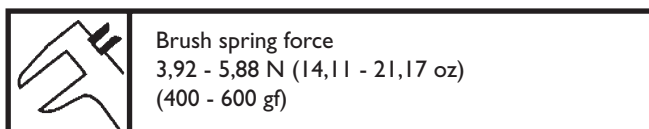

- Check:
  - Gear teeth
  - Damagelwear -> Replace the gear.
- Check:
  - Bearing
  - Oil seal
  - Damagelwear -> Replace the starter motor front cover/brush holder set.

## ASSEMBLING THE STARTER MOTOR

- Install:
  - Starter motor front cover/brush holder set "1"
  - Starter motor yoke "2"

NOTE  
ALIGN THE MARKS "a" ON THE STARTER MOTOR YOKE AND  
STARTER MOTOR FRONT COVER/BRUSH HOLDER SET.

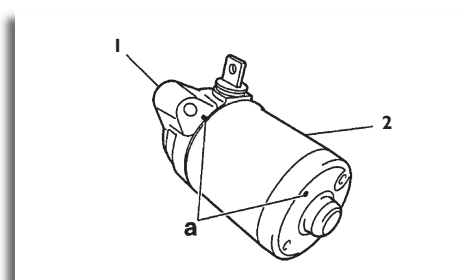

**CLUTCH**

Removing the clutch cover

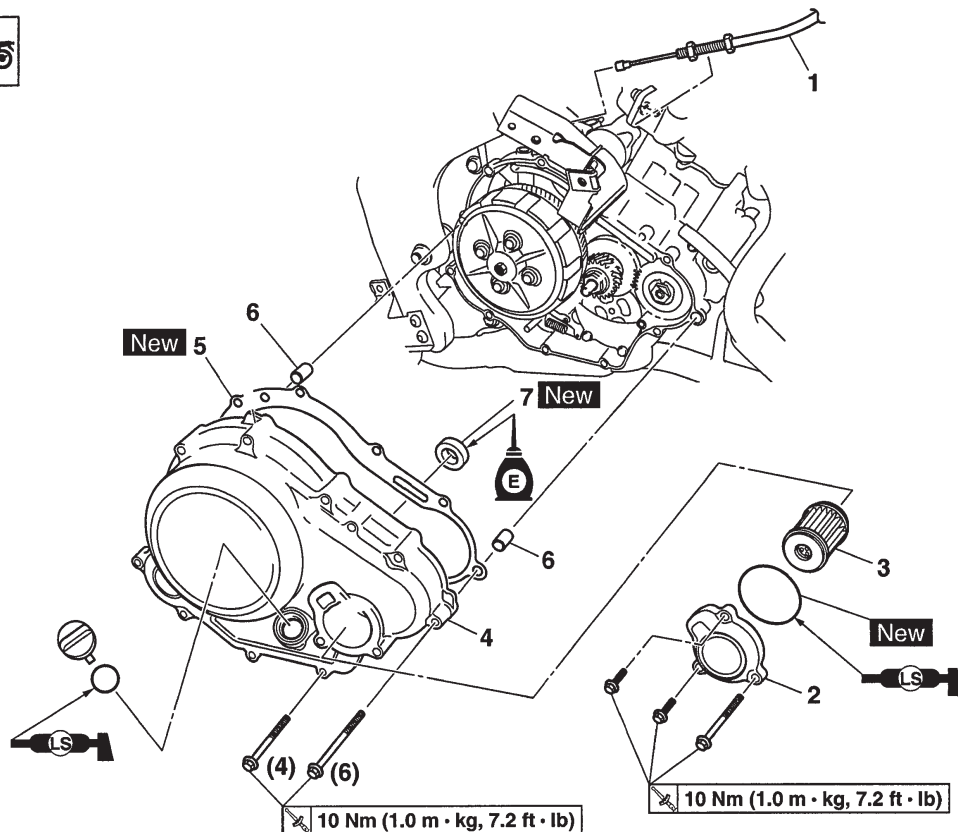

Order	Job/Parts to remove	Q'ty	Remarks
	Engine oil		Drain
1	Clutch cable	1	Disconnect
2	Oil filter element cover	1	
3	Oil filter element	1	
4	Clutch cover	1	
5	Clutch cover gasket	1	
6	Dowel pin	2	
7	Oil seal	1	
			For installation, reverse the removal procedure.

**CLUTCH**

Removing the clutch

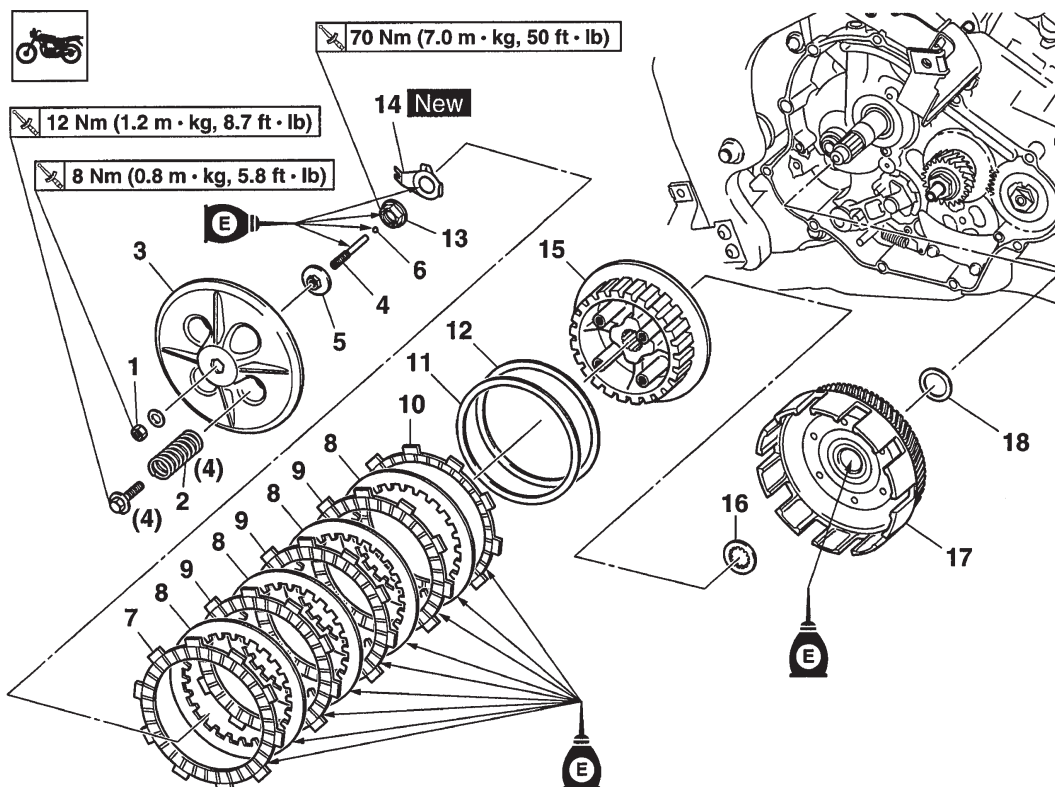

Order	Job/Parts to remove	Q'ty	Remarks
1	Locknut	1	
2	Clutch spring	4	
3	Pressure plate	1	
4	Short clutch push rod	1	
5	Clutch push rod holder	1	
6	Ball	1	
7	Friction plate 1	1	
8	Clutch plate	4	
9	Friction plate 3 (Green)	3	
10	Friction plate 2	1	
11	Clutch damper spring	1	
12	Clutch damper spring seat	1	
13	Clutch boss nut	1	
14	Lock washer	1	

**CLUTCH**

Removing the clutch

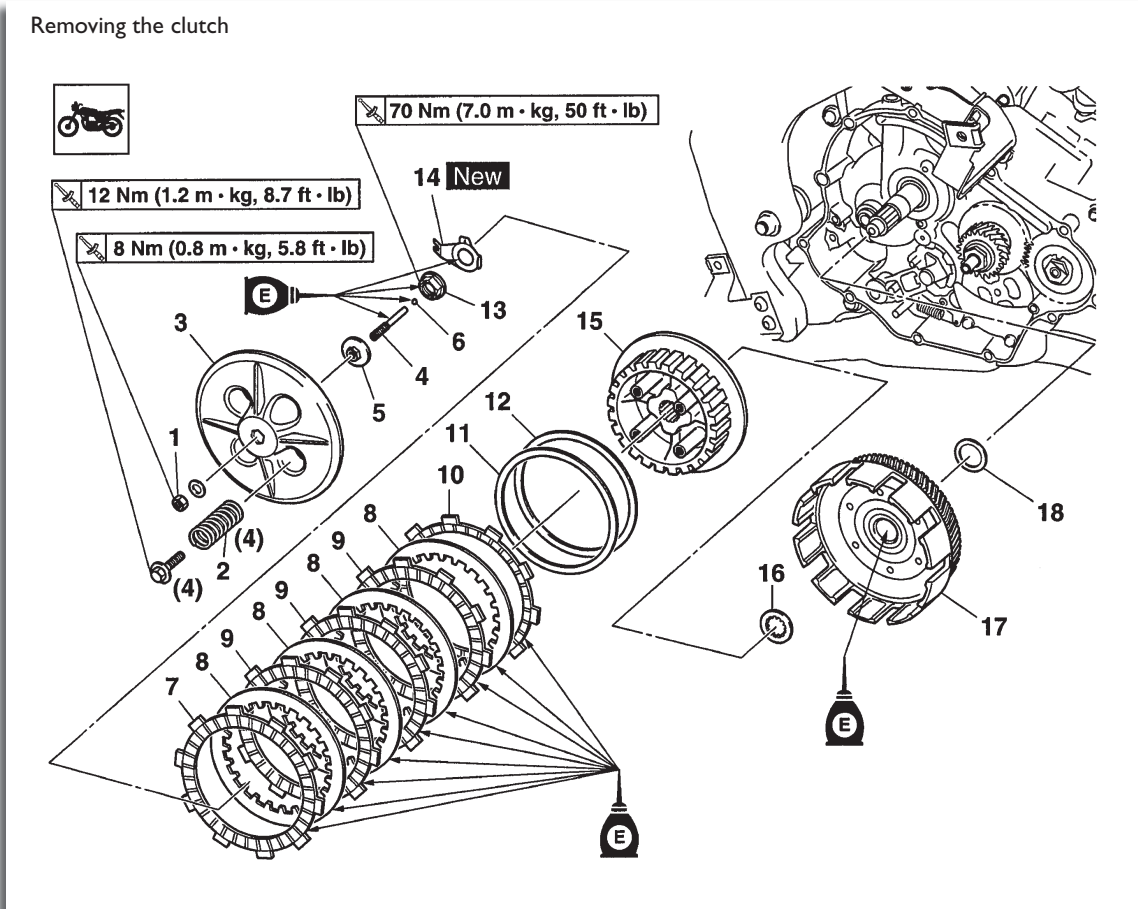

Order	Job/Parts to remove	Q'ty	Remarks
15	Clutch boss	1	
16	Thrust washer	1	
17	Clutch housing	1	
18	Conical spring washer	1	
			For installation, reverse the removal procedure.

**CLUTCH**

Removing the push lever

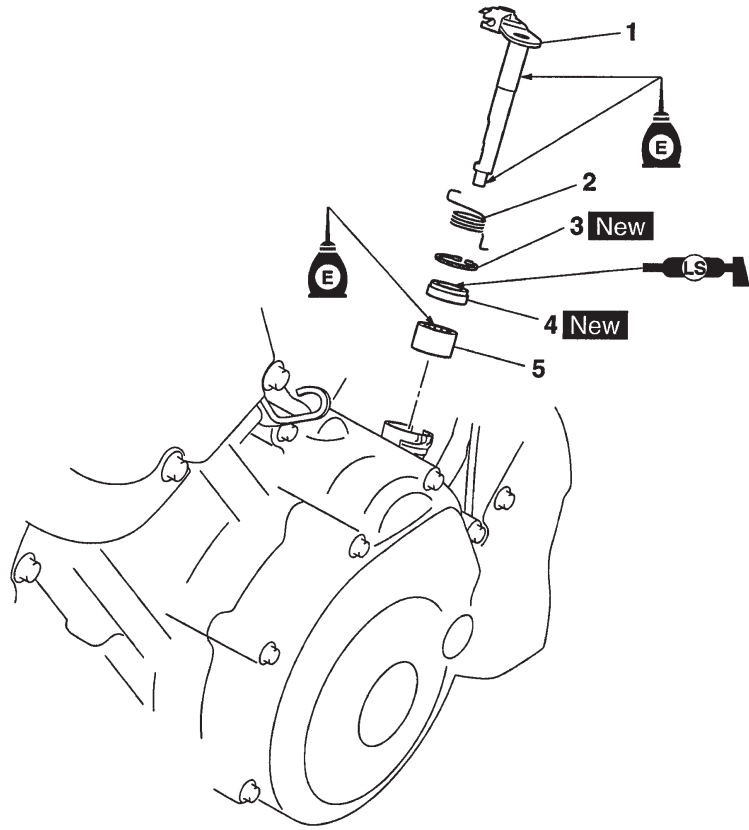



Order	Job/Parts to remove	Q'ty	Remarks
1	Clutch push lever	1	
2	Clutch push lever spring	1	
3	Circlip	1	
4	Oil seal	1	
5	Bearing	1	
			For installation, reverse the removal procedure.

## REMOVING THE CLUTCH

- Straighten the lock washer tab.
- Loosen:
  - Clutch boss nut "1"

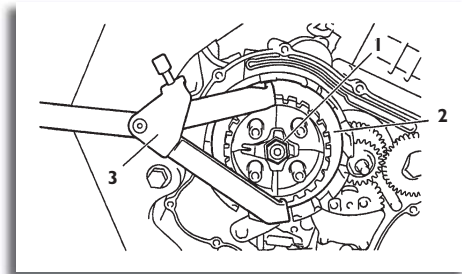
**NOTE**  
 WHILE HOLDING THE CLUTCH BOSS " 2 WITH THE UNIVERSAL CLUTCH HOLDER "3", LOOSEN THE CLUTCH BOSS NUT.



	Universal clutch holder 90890-04086 YM-91042
---	--

## CHECKING THE FRICTION PLATES

The following procedure applies to all of the friction plates.

- Check:
  - Friction plate  
 Damagelwear -> Replace the friction plates as a set.
- Measure:
  - Friction plate thickness  
 Out of specification Replace the friction plates as a set.

**NOTE**  
 MEASURE THE FRICTION PLATE AT FOUR PLACES.

	Friction plate 1 thickness 2,90 - 3,10 mm (0,114 - 0,122 in) Wear limit 2,80 mm (0,110 in) Friction plate 2 thickness 2,90 - 3,10 mm (0,114 - 0,122 in) Wear limit 2,80 mm (0,1102 in) Friction plate 3 thickness 2,90 - 3,10 mm (0,114 - 0,122 in) Wear limit 2,80 mm (0,1102 in)
---	---



- A. Friction plate 1
- B. Friction plate 2
- C. Friction plate 3 (Green)
- a. Green paint

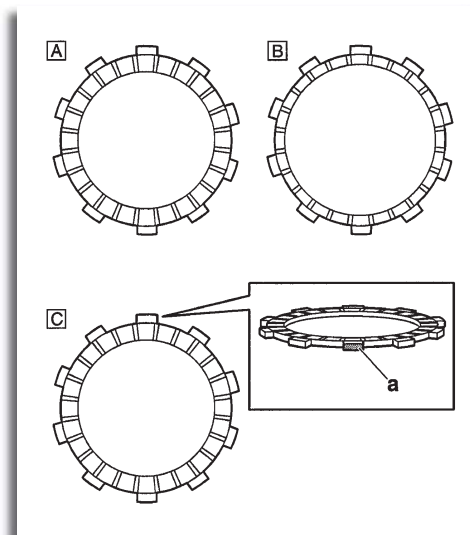
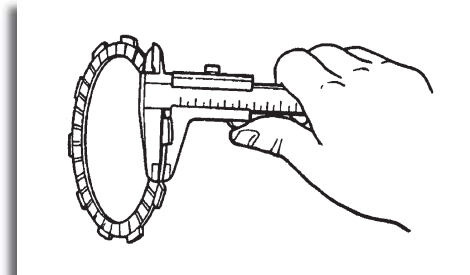

**CHECKING THE CLUTCH PLATES**

The following procedure applies to all of the clutch plates.

- Check:
  - Clutch plate
  - Damage -> Replace the clutch plates as a set.
- Measure:
  - Clutch plate warpage
  - (with a surface plate and thickness gauge "1")
  - Out of specification -> Replace the clutch plates as a set.

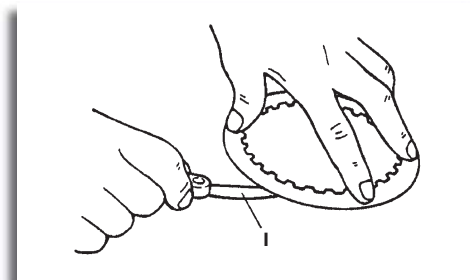

	Thickness gauge 90890-03180 Feeler gauge set YU-26900-9
--	--

	Clutch plate thickness 1,45 - 1,75 mm (0,057 - 0,069 in) Warpage limit 0,20 mm (0,0079 in)
--	---

## CHECKING THE CLUTCH SPRINGS

The following procedure applies to all of the clutch springs.

- Check:
  - Clutch spring
  - Damage -> Replace the clutch springs as a set.
- Measure:
  - Clutch spring free length "a"
  - Out of specification -> Replace the clutch springs as a set.

	Clutch spring free length 38,71 mm (1,52 in) Minimum length 36,77 mm (1,45 in)
---	---

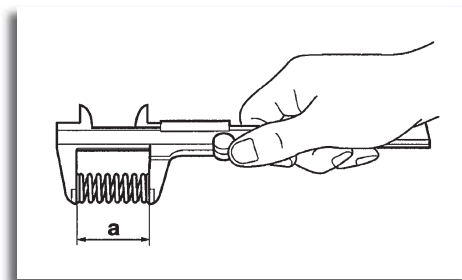

## CHECKING THE CLUTCH HOUSING

- Check:
  - Clutch housing dogs "I"
  - Damage/pitting/wear -> Deburr the clutch housing dogs or replace the clutch housing.

NOTE  
PITTING ON THE CLUTCH HOUSING DOGS WILL CAUSE ERRATIC CLUTCH OPERATION.

- Check:
  - Bearing
  - Damagelpittingwear -> Replace the bearing and clutch housing.

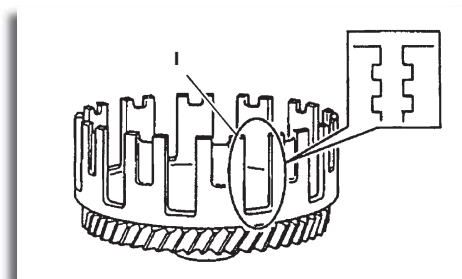

## CHECKING THE CLUTCH BOSS

- Check:
  - Clutch boss splines
  - Damagelpittingwear -> Replace the clutch boss.

NOTE  
PITTING ON THE CLUTCH BOSS SPLINES WILL CAUSE ERRATIC CLUTCH OPERATION

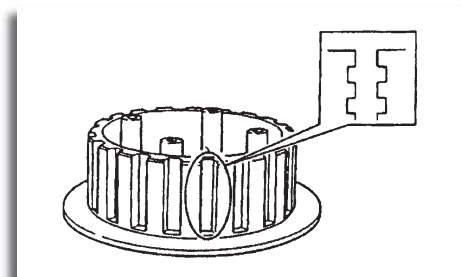

## CHECKING THE PRESSURE PLATE

---

- Check:
  - Pressure plate  
Cracks/damage -> Replace.

## CHECKING THE CLUTCH PUSH LEVER AND SHORT CLUTCH PUSH ROD

---

- Check:
  - Clutch push lever  
Short clutch push rod  
Damage/wear -> Replace the defective part(s).

## CHECKING THE PRIMARY DRIVE GEAR

---

- Remove:
  - Primary drive gear  
Refer to "BALANCER GEAR"
- Check:
  - Primary drive gear  
Damage/wear -> Replace the primary drive gear and clutch housing as a set.  
Excessive noise during operation -> Replace the primary drive gear and clutch housing as a set.
- Install:
  - Primary drive gear  
Refer to "BALANCER GEAR"

## CHECKING THE PRIMARY DRIVEN GEAR

---

- Check:
  - Primary driven gear "I"  
Damage/wear -> Replace the primary drive gear and clutch housing as a set.  
Excessive noise during operation -> Replace the primary drive gear and clutch housing as a set.

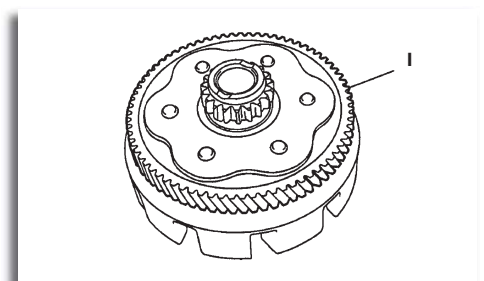

**INSTALLING THE CLUTCH**

- Install:
  - Conical spring washer "1"

NOTE  
 INSTALL THE CONICAL SPRING WASHER AS SHOWN IN THE ILLUSTRATION.

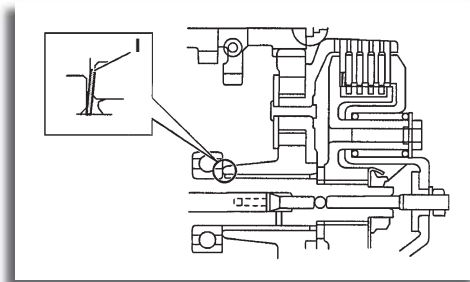

- Install:
  - Clutch housing
  - Thrust washer "1"

NOTE  
 BE SURE TO INSTALL THE THRUST WASHER SO THAT ITS SHARP EDGE "A" IS FACING AWAY FROM THE CLUTCH BOSS.

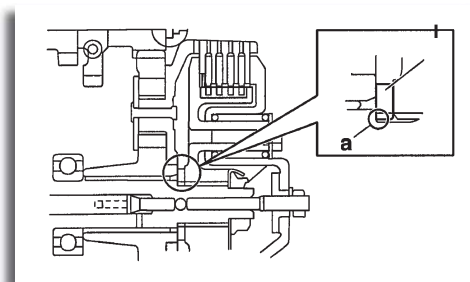

- Install:
  - Clutch boss "1"
  - Lock washer "2" - New
  - Clutch boss nut

NOTE  
 LUBRICATE THE CLUTCH BOSS NUT THREADS AND LOCK WASHER MATING SURFACES WITH ENGINE OIL.

ALIGN THE NOTCH "a" IN THE LOCK WASHER WITH A RIB "b" ON THE CLUTCH BOSS.

- Tighten:
  - Clutch boss nut "1"

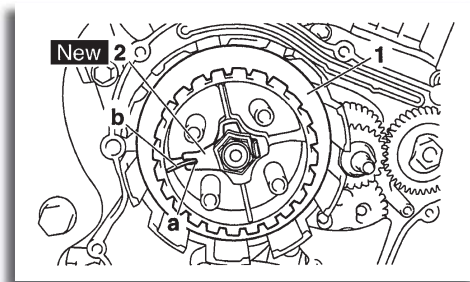

	<p>Clutch boss nut                  70 Nm (7,0 m-kg, 50 ft-lb)</p>
--	--

NOTE  
 WHILE HOLDING THE CLUTCH BOSS "2" WITH THE UNIVERSAL CLUTCH HOLDER "3", TIGHTEN THE CLUTCH BOSS NUT.

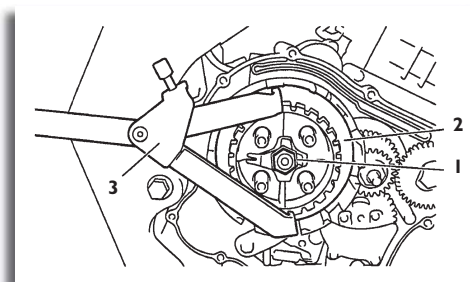

	<p>Universal clutch holder                  90890-04086                  YM-91042</p>
--	---

- Bend the lock washer tab along a flat side of the nut.
- Lubricate:
  - Friction plates
  - Clutch plates  
(with the recommended lubricant)

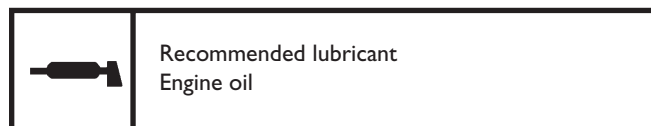

- Install:
  - Clutch damper spring seat "1"
  - Clutch damper spring "2"
  - Friction plate 2
  - Clutch plates
  - Friction plates 3
  - Friction plate 1

**NOTE**

INSTALL THE CLUTCH DAMPER SPRING SEAT AND CLUTCH DAMPER SPRING AS SHOWN IN THE ILLUSTRATION.

FIRST, INSTALL A FRICTION PLATE AND THEN ALTERNATE BETWEEN A CLUTCH PLATE AND A FRICTION PLATE.

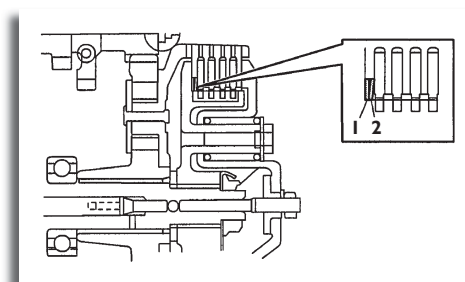

- Install:
  - Pressure plate
  - Clutch springs
  - Clutch spring bolts "1"

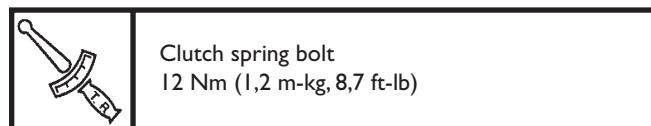
**NOTE**

TIGHTEN THE CLUTCH SPRING BOLTS IN STAGES AND IN A CRISSCROSS PATTERN.

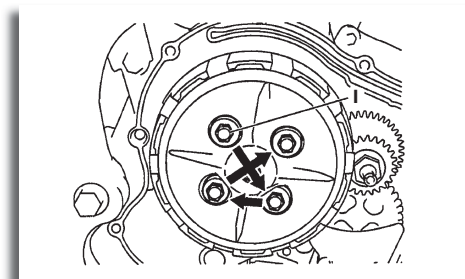

- Adjust:
  - Clutch mechanism free play.

Engine

a) Check that projection “a” on the clutch push lever “1” aligns with mark “b” shown on the crankcase in the illustration by pushing the clutch push lever manually in direction “c” until it stops.

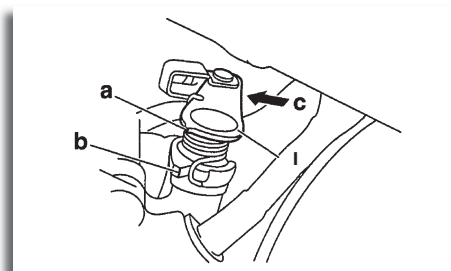

b) If projection “a” is not aligned with mark “b”, align them as follows:

- Loosen the locknut “2”.
- With the clutch push lever fully pushed in direction “c”, turn the short clutch push rod “3” in or out until projection “a” aligns with mark “b”.
- Hold the short clutch push rod to prevent it from moving and then tighten the locknut to specification.



Short clutch push rod locknut  
8 Nm (0,8 m-kg, 5,8 ft-lb)

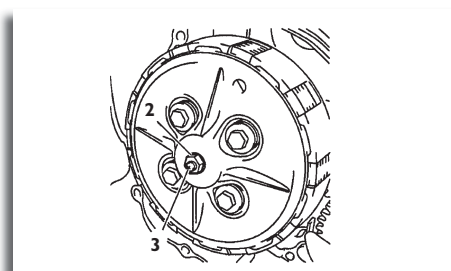

- Install:
  - Oil seal “1”



Installed depth of oil seal “a”  
1,4 - 1,9 mm (0,055 - 0,075”)

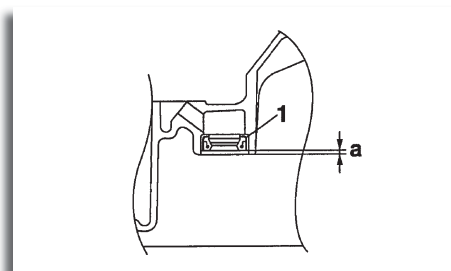

- Install:
  - Clutch cover.



Clutch cover bolt  
10 Nm (1,0 m-kg, 7,2 ft-lb)

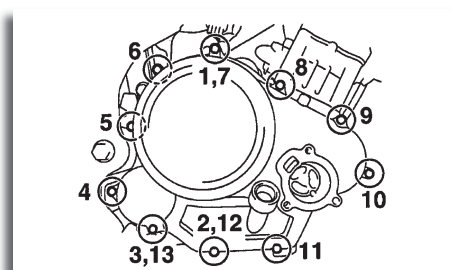

NOTE  
TIGHTEN THE CLUTCH COVER BOLTS IN THE PROPER TIGHTENING SEQUENCE AS SHOWN.

- Adjust:
  - Clutch cable free play  
Refer to “ADJUSTING THE CLUTCH CABLE FREE PLAY”

**OIL PUMP**

Disassembling the oil pump

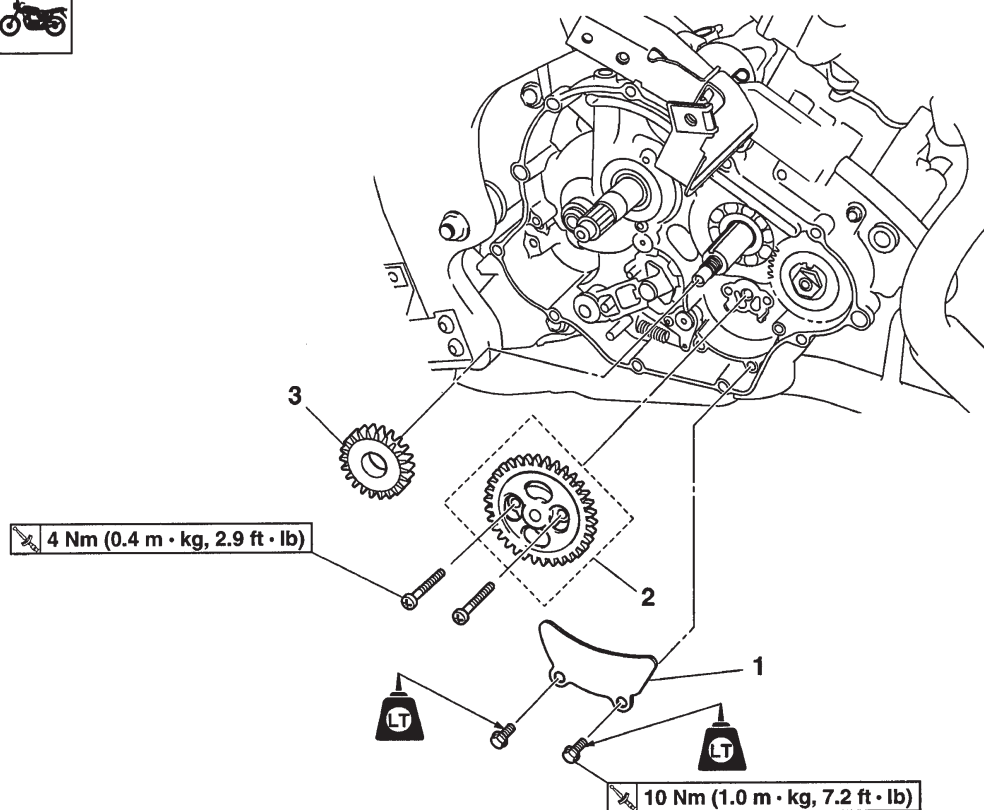

Order	Job/Parts to remove	Q'ty	Remarks
	Clutch housing		
	Balancer drive gear		
1	Oil baffle plate	1	
2	Oil pump assembly	1	
3	Oil pump drive gear	1	
			For installation, reverse the removal procedure.

**OIL PUMP**

Disassembling the oil pump

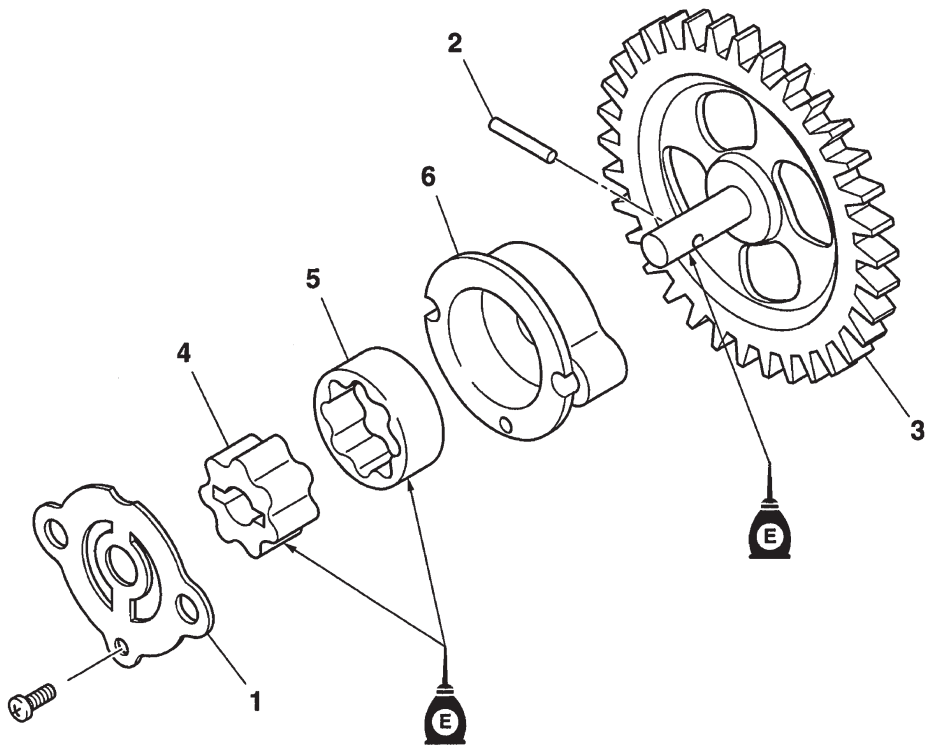

Order	Job/Parts to remove	Q'ty	Remarks
1	Oil pump housing cover	1	
2	Pin	1	
3	Oil pump driven gear	1	
4	Oil pump inner rotor	1	
5	Oil pump outer rotor	1	
6	Oil pump housing	1	
			For installation, reverse the removal procedure.



## CHECKING THE OIL PUMP

- Check:
  - Oil pump drive gear
  - Oil pump driven gear
  - Oil pump housing
  - Oil pump housing cover
 Cracks/damage/wear -> Replace the defective part(s).
  
- Measure:
  - Inner-rotor-to-outer-rotor-tip clearance "a"
  - Outer-rotor-to-oil-pump-housing clearance "b"
  - Oil-pump-housing-to-inner-rotor and outerrotor clearance "c"
 Out of specification -> Replace the oil pump.

1. Inner rotor
2. Outer rotor
3. Oil pump housing

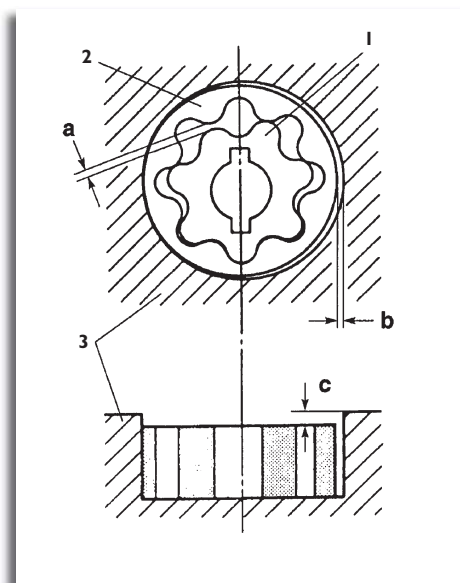

Inner-rotor-to-outer-rotor-tip del rotor clearance  
Less than 0,15 mm (0,0059 in)

Limit  
0,23 mm (0,0091 in)

Outer-rotor-to-oil-pump-housing  
clearance  
0,13 - 0,18 mm (0,0051 - 0,0071 in)

Limit  
0,25 mm (0,0098 in)

Oil-pump-housing-to-inner-and-outer-  
rotor clearance  
0,06 - 0,11 mm (0,0024 - 0,0043 in)

Limite  
0,18 mm (0,0071 in)

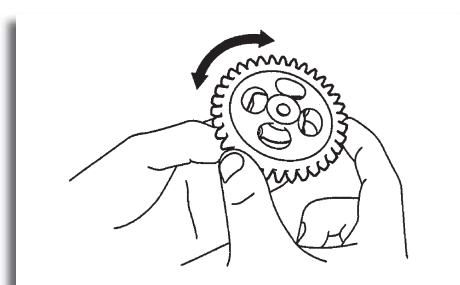

- Check:
  - Oil pump operation
 Rough movement -> Repeat steps (1) and (2) or replace the defective part(s).

## ASSEMBLING THE OIL PUMP

- Lubricate:
  - Oil pump inner rotor
  - Oil pump outer rotor
  - Oil pump driven gear  
(with the recommended lubricant)

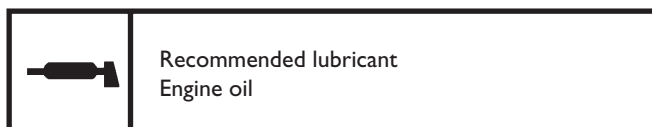

- Install:
  - Oil pump outer rotor
  - Oil pump inner rotor "1"
  - Oil pump driven gear
  - Pin "2"

**NOTE**  
WHEN INSTALLING THE INNER ROTOR, ALIGN THE PIN "2"  
IN THE OIL PUMP SHAFT WITH THE GROOVE "a" IN THE IN-  
NER ROTOR "1".

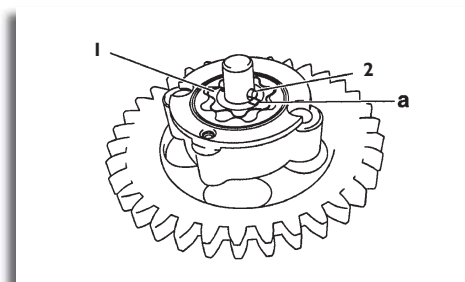

- Check:
  - Oil pump operation  
Refer to "CHECKING THE OIL PUMP"

## INSTALLING THE OIL PUMP

- Install:
  - Oil pump assembly

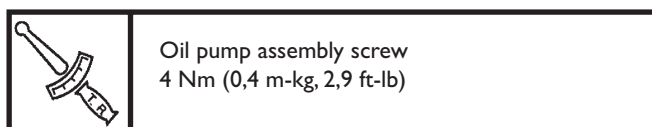

**CAUTION**  
AFTER TIGHTENING THE SCREWS, MAKE SURE THE OIL PUMP  
TURNS SMOOTHLY.

**SHIFT SHAFT**

Removing the primary drive gear and balancer gears

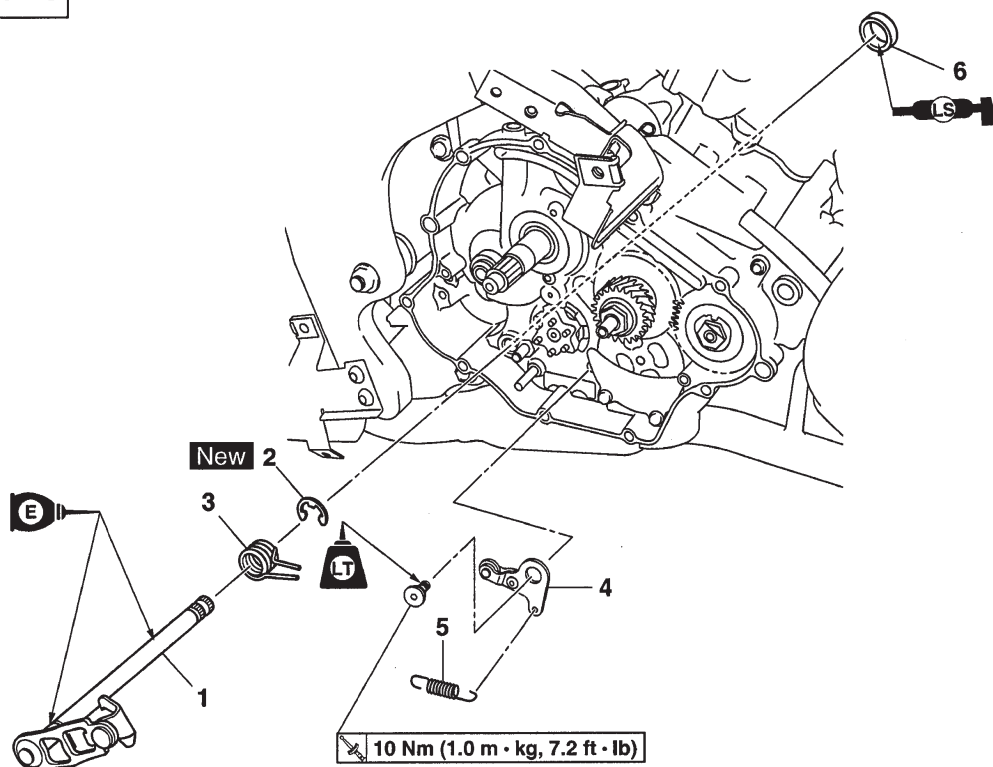

Order	Job/Parts to remove	Q'ty	Remarks
	Clutch housing		
	Shift arm		
1	Shift shaft	1	
2	Circlip	1	
3	Shift shaft spring	1	
4	Stopper lever	1	
5	Stopper lever spring	1	
6	Oil seal	1	
			For installation, reverse the removal procedure.

## CHECKING THE SHIFT SHAFT

- Check:
  - Shift shaft  
Bends/damage/wear -> Replace.
  - Shift shaft spring  
Damage/wear -> Replace.

## CHECKING THE STOPPER LEVER

- Check:
  - Stopper lever  
Bends/damage -> Replace.  
Roller turns roughly -> Replace the stopper lever.
  - Stopper lever spring  
Damage/wear -> Replace.

## INSTALLING THE STOPPER LEVER

- Install:
  - Stopper lever "1"
  - Stopper lever spring "2"

**NOTE**  
INSTALL THE STOPPER LEVER SPRING AS SHOWN IN THE ILLUSTRATION.

HOOK THE ENDS OF THE STOPPER LEVER SPRING ONTO THE STOPPER LEVER AND THE CRANKCASE BOSS "3".

MESH THE STOPPER LEVER WITH THE SHIFT DRUM SEGMENT ASSEMBLY.

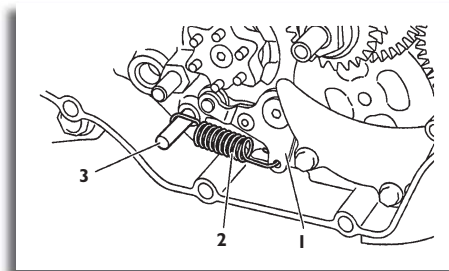

- Install:
  - Shift shaft "1"

**NOTE**  
HOOK THE END OF THE SHIFT SHAFT SPRING ONTO THE SHIFT SHAFT SPRING STOPPER "2".

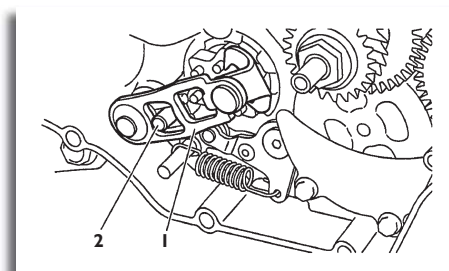

**BALANCER GEAR**

Removing the primary drive gear and balancer gears

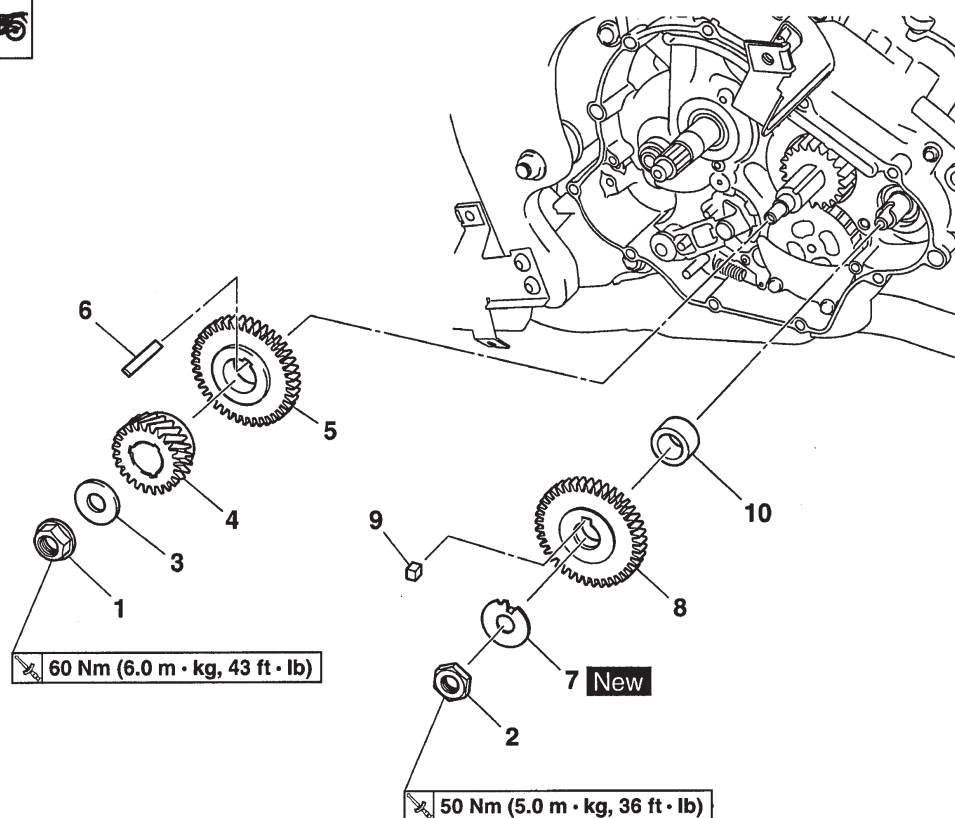

Order	Job/Parts to remove	Q'ty	Remarks
	Clutch housing		
1	Primary drive gear nut	1	
2	Balancer driven gear nut	1	
3	Washer	1	
4	Primary drive gear	1	
5	Balancer drive gear	1	
6	Straight key	1	
7	Lock washer	1	
8	Balancer driven gear	1	
9	Straight key	1	
10	Spacer	1	
			For installation, reverse the removal procedure.

## REMOVING THE PRIMARY DRIVE GEAR AND BALANCER GEARS

- Loosen:
  - Primary drive gear nut "1"

### NOTE

PLACE THE ALUMINUM PLATE "a" BETWEEN THE BALANCER DRIVE GEAR "2" AND THE BALANCER DRIVEN GEAR "3", AND THEN LOOSEN THE PRIMARY DRIVE GEAR NUT.

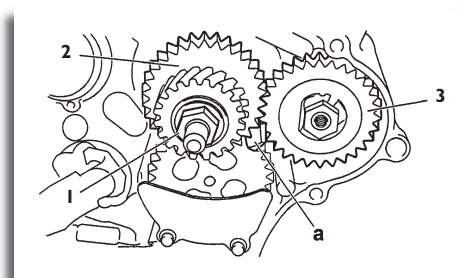

- Straighten the lock washer tab.

- Loosen:
  - Balancer driven gear nut "1"

### NOTE

PLACE THE ALUMINUM PLATE "a" BETWEEN THE BALANCER DRIVE GEAR "2" THE AND THE BALANCER DRIVEN GEAR "3", AND THEN LOOSEN THE BALANCER DRIVEN GEAR NUT.

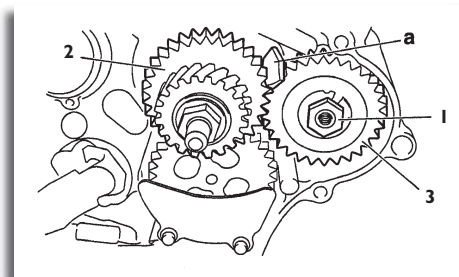

## CHECKING THE BALANCER GEARS AND PRIMARY DRIVE GEAR

- Check:
  - Balancer drive gear
  - Balancer driven gear
  - Cracks/damage/wear -> Replace.
- Check:
  - Primary drive gear

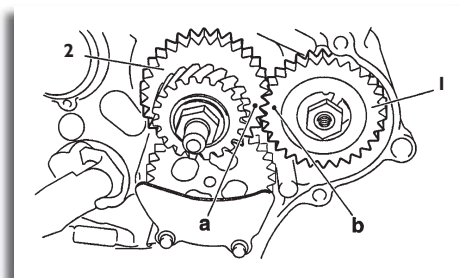

## INSTALLING THE PRIMARY DRIVE GEAR AND BALANCER GEARS

- Install:
  - Balancer driven gear "1"
  - Lock washer - New
  - Balancer drive gear "2"
  - Primary drive gear
  - Washer "3"
  - Balancer driven gear nut
  - Primary drive gear nut

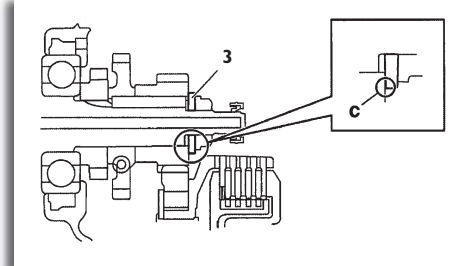

**NOTE**

ALIGN THE PUNCH MARK "a" IN THE BALANCER DRIVE GEAR "2" WITH THE PUNCH MARK "b" IN THE BALANCER DRIVEN GEAR "1".

BE SURE TO INSTALL THE WASHER SO THAT ITS SHARP EDGE "c" IS FACING THE PRIMARY DRIVE GEAR.

• Tighten:

- Balancer driven gear nut "1"
- Primary drive gear nut "2"



Balancer driven gear nut  
50 Nm (5,0 m-kg, 36 ft-lb)

Primary drive gear nut  
60 Nm (6,0 m-kg, 43 ft-lb)

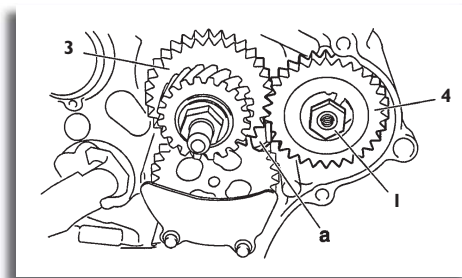

**NOTE**

PLACE THE ALUMINUM PLATE "a" BETWEEN THE BALANCER DRIVE GEAR "3" AND THE BALANCER DRIVEN GEAR "4", AND THEN TIGHTEN THE BALANCER DRIVEN GEAR NUT.

PLACE THE ALUMINUM PLATE "b" BETWEEN THE BALANCER DRIVE GEAR "3" AND THE BALANCER DRIVEN GEAR "4", AND THEN TIGHTEN THE PRIMARY DRIVE GEAR NUT.

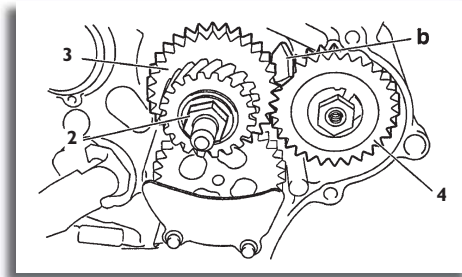

- Bend the lock washer tab along a flat side of the nut.



**CRANKCASE**

Separating the crankcase

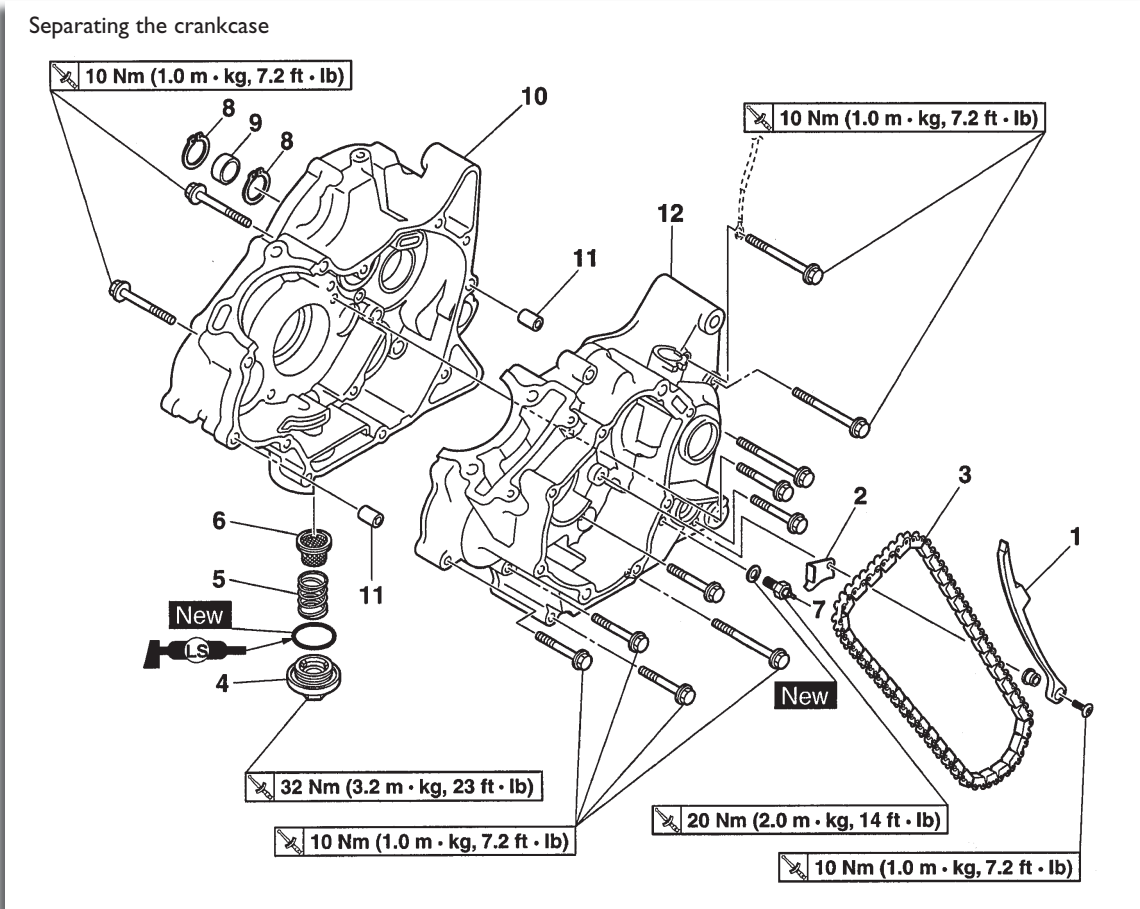

Order	Job/Parts to remove	Q'ty	Remarks
	Engine		
	Cylinder head		
	Cylinder/Piston		
	Clutch housing		
	Oil pump assembly		
	Shift shaft		
	Starter motor		
	Balancer gears		
	Generator rotor		
1	Timing chain guide (intake side)	1	
2	Chain cover	1	
3	Timing chain	1	
4	Engine oil drain plug	1	
5	SpringMuelle	1	



**CRANKCASE**

Separating the crankcase

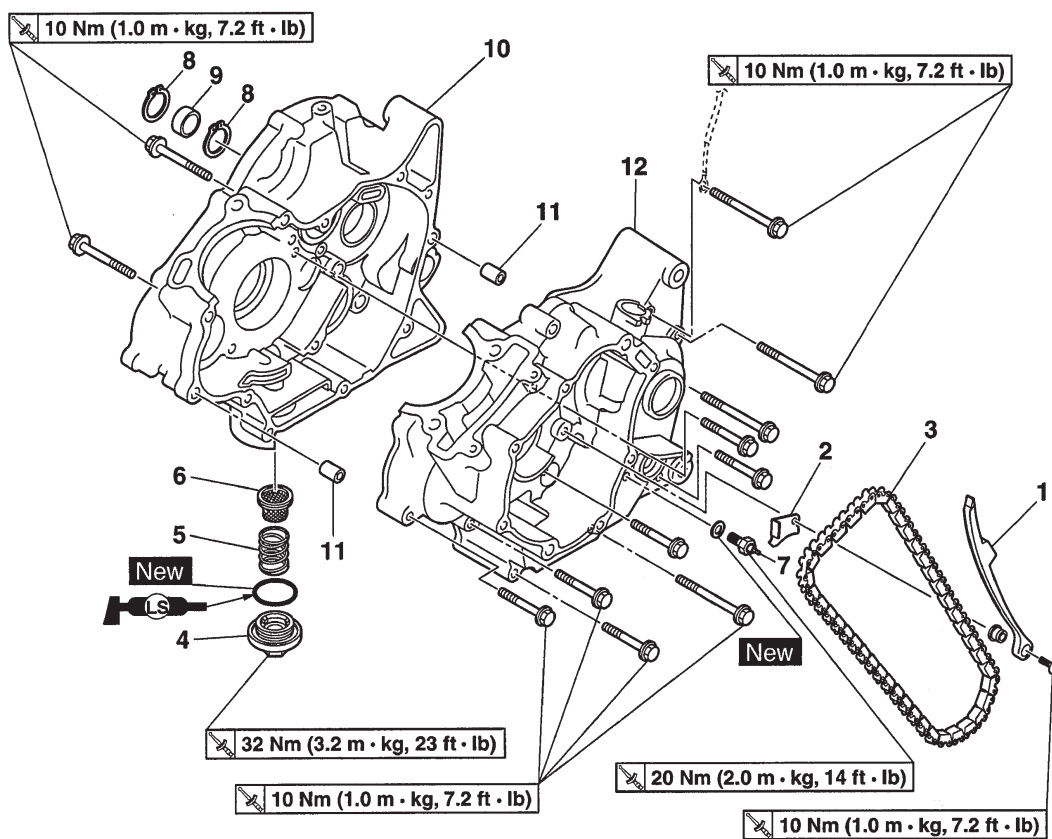

Order	Job/Parts to remove	Q'ty	Remarks
6	Engine oil strainer	1	
7	Neutral switch	1	
8	Circlip	2	
9	S pacer	1	
10	Right crankcase	1	
11	Dowel pin	2	
12	Left crankcase	1	
			For installation, reverse the removal procedure.

**CRANKCASE**

Removing the oil seal and bearings

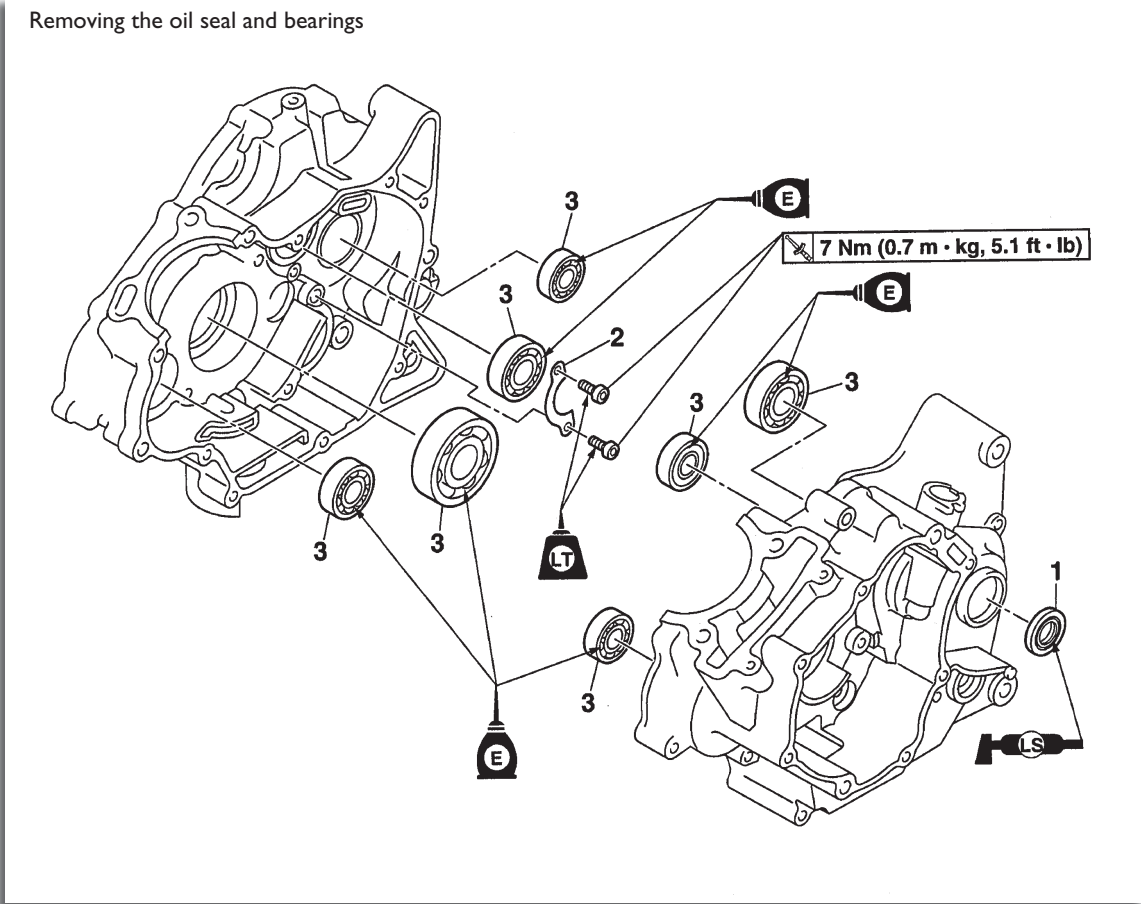

Order	Job/Parts to remove	Q'ty	Remarks
	Crankshaft/Balancer		
	Transmission		
1	Oil seal	1	
2	Bearing retainer	1	
3	Bearing	7	
			For installation, reverse the removal procedure.

## SEPARATING THE CRANKCASE

- Remove:
  - Crankcase bolts

### NOTE

LOOSEN EACH BOLT 1/4 OF A TURN AT A TIME, IN STAGES AND IN THE PROPER SEQUENCE AS SHOWN.

- A. Right crankcase*
- B. Left crankcase*

- Turn:
  - Shift drum segment

### NOTE

TURN THE SHIFT DRUM SEGMENT "1" TO THE POSITION SHOWN IN THE ILLUSTRATION. IN THIS POSITION, THE SHIFT DRUM SEGMENT TEETH WILL NOT CONTACT THE CRANKCASE DURING CRANKCASE SEPARATION.

- Remove:
  - Right crankcase

### CAUTION

TAP ON ONE SIDE OF THE CRANKCASE WITH A SOFTFACE HAMMER. TAP ONLY ON REINFORCED PORTIONS OF THE CRANKCASE, NOT ON THE CRANKCASE MATING SURFACES. WORK SLOWLY AND CAREFULLY AND MAKE SURE THE CRANKCASE HALVES SEPARATE EVENLY.

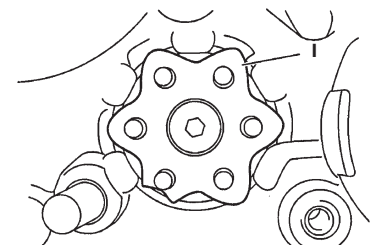
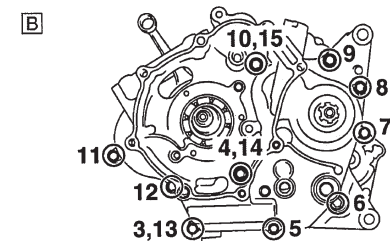
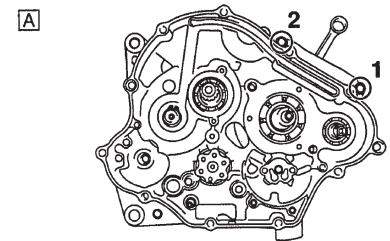

## CHECKING THE CRANKCASE

- Thoroughly wash the crankcase halves in a mild solvent.
- Thoroughly clean all the gasket surfaces and crankcase mating surfaces.
- Check:
  - Crankcase
    - Cracks/damage -> Replace.
  - Oil delivery passages
    - Obstruction -> Blow out with compressed air.

## CHECKING THE TIMING CHAIN AND TIMING CHAIN GUIDE

- Check:
  - Timing chain
    - Damagelstiffness -> Replace the timing chain and camshaft sprocket as a set.
- Check:
  - Timing chain guide (intake side)
    - Damagelwear -> Replace.

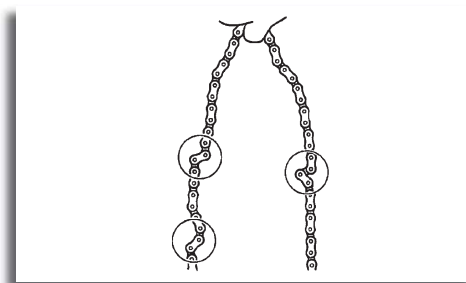

## CHECKING THE OIL STRAINER

- Check:
  - Oil strainer
    - Damage -> Replace.
    - Contaminants -> Clean with solvent.

## CHECKING THE BEARINGS AND OIL SEAL

- Check:
  - Bearings
    - Clean and lubricate the bearings, and then rotate the inner race with your finger.
    - Rough movement -> Replace.
- Oil seal
  - Damagelwear -> Replace.

## INSTALLING THE BEARING RETAINER

- Install:
  - Bearing retainer "I"

### NOTE

INSTALL THE BEARING RETAINER "I" WITH ITS "OUT" MARK "A" FACING OUTWARD.

APPLY LOCKING AGENT (LOCTITE®) TO THE THREADS OF THE BEARING RETAINER BOLT.

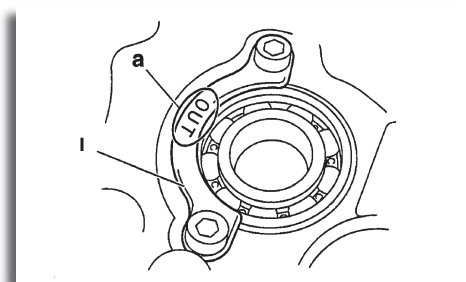

Bearing retainer bolt  
7 Nm (0,7 m-kg, 5,1 ft-lb)  
LOCTITE®

### ASSEMBLING THE CRANKCASE

• Thoroughly clean all the gasket mating surfaces and crankcase mating surfaces.

- Apply:
  - Sealant  
(onto the crankcase mating surfaces)

	Yamaha bond n° 1215 90890-85505 (Three Bond n° 1215®)
---	---

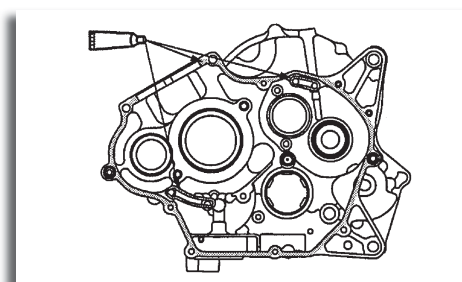

**NOTE**  
DO NOT ALLOW ANY SEALANT TO COME INTO CONTACT WITH THE OIL GALLERY.

- Install:
  - Right crankcase

**NOTE**  
TURN THE SHIFT DRUM SEGMENT "1" TO THE POSITION SHOWN IN THE ILLUSTRATION. IN THIS POSITION, THE SHIFT DRUM SEGMENT TEETH WILL NOT CONTACT THE CRANKCASE DURING CRANKCASE INSTALLATION.

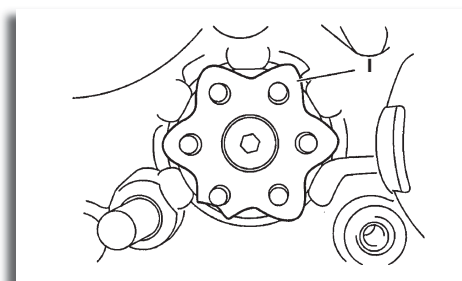

- Install:
  - Crankcase bolts

	Crankcase bolt 10 Nm (1,0 m·kg, 7,2 ft·lb)
---	---

**NOTE**  
TIGHTEN EACH BOLT 1/4 OF A TURN AT A TIME, IN STAGES AND IN THE PROPER SEQUENCE AS SHOWN.

- M6 x 70 mm: "7-9", "11"
- M6 x 55 mm: "14", "15"
- M6 x 45 mm: "1-5", "10"

A. Left crankcase  
B. Right crankcase

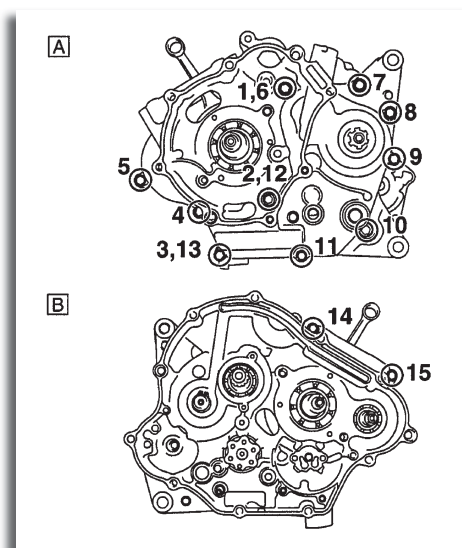

**CRANKSHAFT**

Removing the crankshaft and balancer

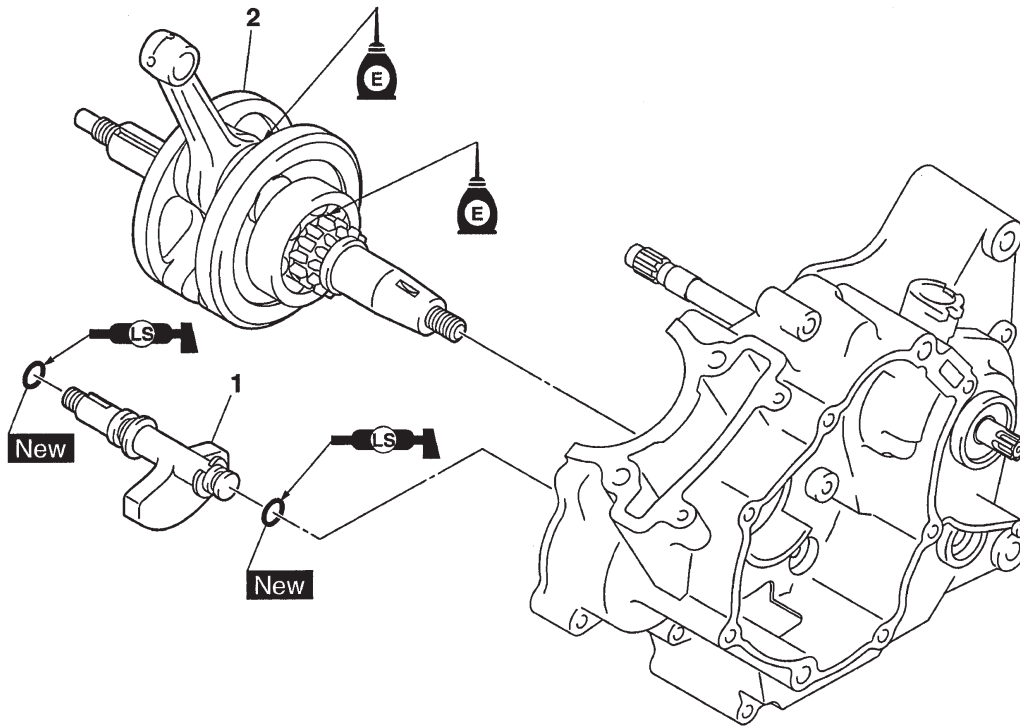

Order	Job/Parts to remove	Q'ty	Remarks
	Crankcase		
1	Balancer	1	
2	Crankshaft	1	
			For installation, reverse the removal procedure.

## REMOVING THE CRANKSHAFT

- Remove:
  - Crankshaft "1"

**NOTE**  
REMOVE THE CRANKSHAFT WITH THE CRANKCASE SEPARATING TOOL "2".

MAKE SURE THE CRANKCASE SEPARATING TOOL IS CENTERED OVER THE CRANKSHAFT.

**CAUTION**  
TO PROTECT THE END OF THE CRANKSHAFT, PLACE AN APPROPRIATE SIZED SOCKET BETWEEN THE CRANKCASE SEPARATING TOOL BOLT AND THE CRANKSHAFT.

DO NOT TAP ON THE CRANKSHAFT.

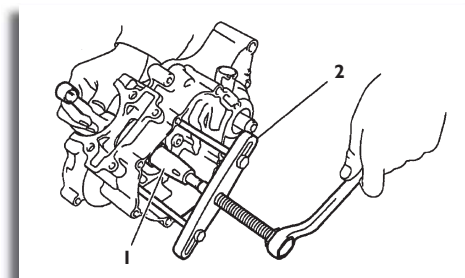

	Crankcase separating tool 90890-01135 Crankcase separator YU-01135-B
--	---

## CHECKING THE CRANKSHAFT

- Measure:
  - Crankshaft runout  
Out of specification -> Replace the crankshaft, bearing or both.

**NOTE**  
TURN THE CRANKSHAFT SLOWLY.

	Runout limit C 0,030 mm (0,0012")
---	--------------------------------------

- Measure:
  - Big end side clearance  
Out of specification -> Replace the crankcase

	Big end side clearance D 0,110 - 0,410 mm (0,0043 - 0,0161")
---	---

- Measure:
  - Crankshaft width  
Out of specification -> Replace the crankshaft.

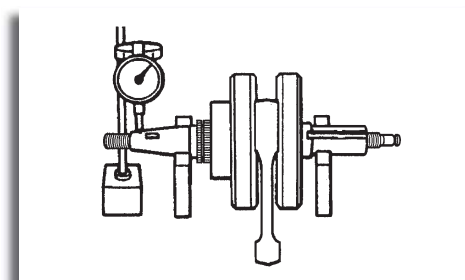



- Check:
  - Crankshaft sprocket  
Damagelwear -> Replace the cran kshaft.
  - Bearing  
Cracks/damage/wear -> Replace the cran kshaft.
- Check:
  - Crankshaft journal  
Scratches/wear -> Replace the cran kshaft.
  - Crankshaft journal oil passage  
Obstruction -> Blow out with compressed air.

## INSTALLING THE CRANKSHAFT

- Install:
  - Crankshaft "1"

NOTE  
 LNSTALL THE CRANKSHAFT WITH THE CRANKSHAFT INS-  
 TALLER POT "2", CRANKSHAFT INSTALLER BOLT "3", ADAP-  
 TER (M1 2) "4" AND SPACER (CRANKSHAFT INSTALLER) "5".

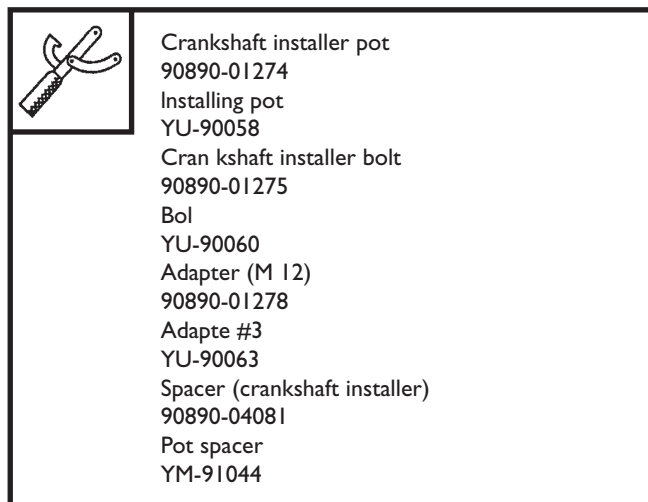
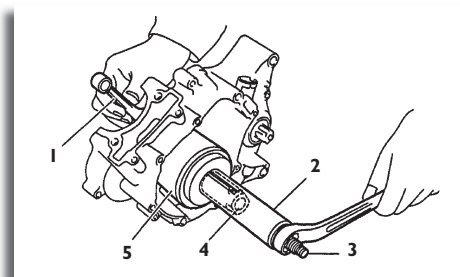

CAUTION  
 TO AVOID SCRATCHING THE CRANKSHAFT AND TO EASE  
 THE INSTALLATION PROCEDURE, LUBRICATE THE OIL SEAL  
 LIPS WITH LITHIUM-SOAP-BASED GREASE AND EACH BEA-  
 RING WITH ENGINE OIL.

NOTE  
 HOLD THE CONNECTING ROD AT TOP DEAD CENTER  
 (TDC) WITH ONE HAND WHILE TURNING THE NUT OF THE  
 CRANKSHAFT INSTALLER BOLT WITH THE OTHER. TURN  
 THE CRANKSHAFT INSTALLER BOLT UNTIL THE CRANKS-  
 HAFT BOTTOMS AGAINST THE BEARING.



**TRANSMISSION**

Removing the transmission, shift drum assembly, and shift forks

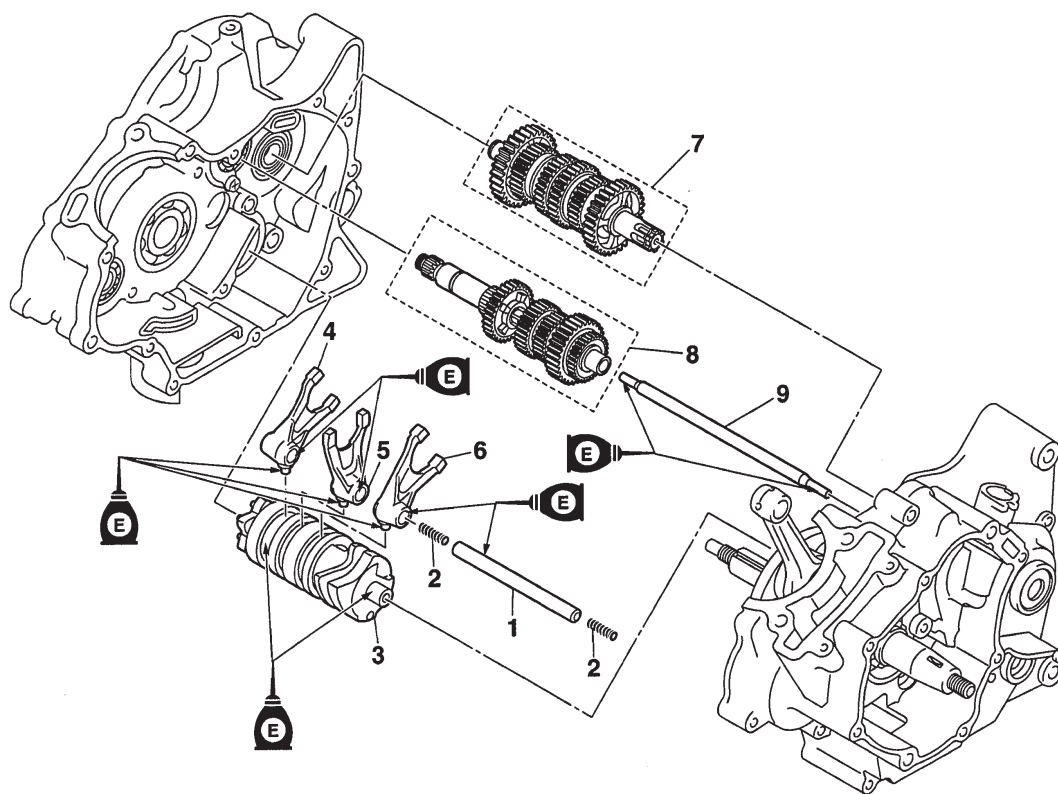

Order	Job/Parts to remove	Q'ty	Remarks
	Crankcase		
1	Shift fork guide bar	1	
2	Spring	2	
3	Shift drum assembly	1	
4	Shift fork-R	1	
5	Shift fork-C	1	
6	Shift fork-L	1	
7	Drive axle assembly	1	
8	Main axle assembly	1	
9	Long clutch push rod	1	
			For installation, reverse the removal procedure.



**RIEJU**

Telf. +34 / 972500850 Fax +34 / 972506950

RIEJU, S.A. c/.Borrassà, 41

E-17600 FIGUERES, GIRONA (SPAIN)

www.riejumoto.com / e-mail [rieju@riejumoto.com](mailto:rieju@riejumoto.com)